

# Model Question Papers

For Undergraduate Programs



**All India Council for Technical Education**  
Nelson Mandela Marg, Vasant Kunj, New Delhi- 110070

# Model Question Papers

For Undergraduate Programs

<b>Programs</b>	<b>Page No.</b>
1. Civil Engineering	CE1-CE14
2. Computer Science and Engineering	CSE1-CSE29
3. Electrical and Electronics Engineering	EEE1-EEE23
4. Electronics and Communication Engineering	ECE1-ECE31
5. Mechanical Engineering	ME1-ME32

# **Civil Engineering**

## **Model Question Papers**

### **For Undergraduate Program**

The model question papers are suggestive blueprints. The primary aim of these question papers is to bring clarity about the process of connecting questions to performance indicators and hence to course outcomes. Further, these question papers demonstrate how bloom's taxonomy can be used to understand the quality of question papers and their effectiveness in assessing higher order abilities. The structure of question papers, number of questions, choices given, time given for examination etc., can vary based on the practices of the University or college.

# Table of Contents

<b>Name of Course</b>	<b>Page No.</b>
1. Advanced Geotechnical Engineering	CE1-CE3
2. Construction Project Management	CE4-CE6
3. Advanced Project Management	CE7-CE9
4. Design of RCC Structures	CE10-CE11
5. Environmental Engineering	CE12-CE14

## Course Name: Advanced Geotechnical Engineering

### Course Outcomes (CO):

At the end of the course the student should be able to:

1. Plan soil exploration program, interpret the results and prepare soil exploration report.
2. Compute active and passive earth pressure.
3. Carry out stability analysis of finite and infinite slopes with some field problem.
4. Compute safe bearing capacity of shallow foundations.
5. Design pile and pile group.
6. Carry out settlement analysis of footings.
7. Assess the potential of soil for the design of landfills and reinforced earth wall.

**Model Question Paper**  
**Total Duration (H:M):3:00**  
**Course :Advanced Geotechnical Engineering**  
**Maximum Marks :100**

Q.No.	Questions	Marks	CO	BL	PO	PI Code
1a	You are appointed as site engineer and have been tasked to carry out site investigations for an earth dam construction site. Describe the investigation procedure and discuss what information is required for the preparation and presentation of the report.	8	CO1	L3	1	1.3.1
1b	A standard penetration test was carried out at a site. The soil profile is given in figure 1(b) below with the penetration values. The average soil data are given for each layer. Compute the corrected values of N and plot showing the variation of observed and corrected values with depth. <div style="text-align: center;"> <p><b>Fig 1(b)</b></p> </div>	6	CO1	L3	4	1.3.1
1c	The unit weight of a soil of a 30° slope is 17.5kN/m <sup>3</sup> . The shear parameters c and φ for the soil are 10 kN/m <sup>2</sup> and 20° respectively. Given that the height of the slope is 12 m and the stability number obtained from the charts for the given slope and angle of internal friction is 0.025, compute the factor of safety.	6	CO3	L2	1	1.3.1
2a	For the retaining wall shown in figure 2(a), draw the active earth pressure distribution diagram and obtain total active force on the wall.	8	CO2	L3	2	2.1.2

	<b>Fig 2(a)</b>					
2b	A retaining wall 4.5 m high with a vertical back supports a horizontal fill weighing $18.60 \text{ kN/m}^3$ and having $\phi = 32^\circ$ , $\delta = 20^\circ$ , and $c = 0$ . Determine the total active thrust on the wall by Culmann's graphical method.	12	CO2	L3	1	1.3.1
3a	A canal having side slope 1:1 is proposed to be constructed in cohesive soils to a depth of 4.5m below the ground surface. The soil properties are a given below; $\phi_u=15^\circ$ , $c_u=10\text{kN/m}^2$ . $e=1.0$ $G=2.65$ . find the factor of safety with respect to cohesion against failure of bank slopes; i) When the canal is full of water and. ii) When there is sudden draw down of water in canal.	8	CO3	L3	2	2.1.2
3b	Determine the depth at which a circular footing 2m diameter be founded to provide a factor of safety of 3.0. If it has to carry a safe load of 1500 kN. The foundation soil has $c=15 \text{ kN/m}^2$ , $\phi=30^\circ$ and unit weight of soil $\gamma=18\text{kN/m}^3$ .	7	CO4	L3	2	2.1.2
3c	A large scale bearing capacity test on a footing of size $1.05\text{m} \times 1.05\text{m}$ at a depth of 1.5m yielded an ultimate value of 141 kN. Unconfined compressive tests on the soft saturated clay yielded a strength of $0.03 \text{ N/mm}^2$ . If the unit weight of the soil is $16 \text{ kN/m}^3$ , how much does the test value differ from that obtained using Terzaghi's bearing capacity equation?	5	CO4	L3	2	2.1.2
4a	Design a pile foundation system in 20 m thick soft clay with undrained cohesion of $60\text{kPa}$ , density of $18\text{kN/m}^3$ and water content of 30%. The clay layer is underlain by hard rock. The pile foundation should carry a load of 6500 kN. Take liquid limit=60%, $G=2.7$ .	12	CO5	L3	2	2.2.3
4b	A soil profile at a site consists of 4.0m of medium sand with dry unit weight of $17 \text{ kN/m}^3$ , underlain by a normally consolidated layer of 2.0m thick clay. The initial void ratio of clay is 1.0 its saturated unit weight is $20 \text{ kN/m}^3$ and its liquid limit is 50%. The ground water table is at the top of the clay layer. A square footing $2\text{m} \times 2\text{m}$ is founded at a depth of 1.0 m below the GL at the site. The load on the footing is 1200 kN. Calculate the settlement of footing due to consolidation of the clay layer.	8	CO6	L3	2	2.1.2
5a	Check the reinforced earth wall shown in figure 5(a) for stability against a) sliding b) over turning and c) bearing failure. Although BC is a rough face, assume it to be smooth.	8	CO7	L3	2	2.1.2

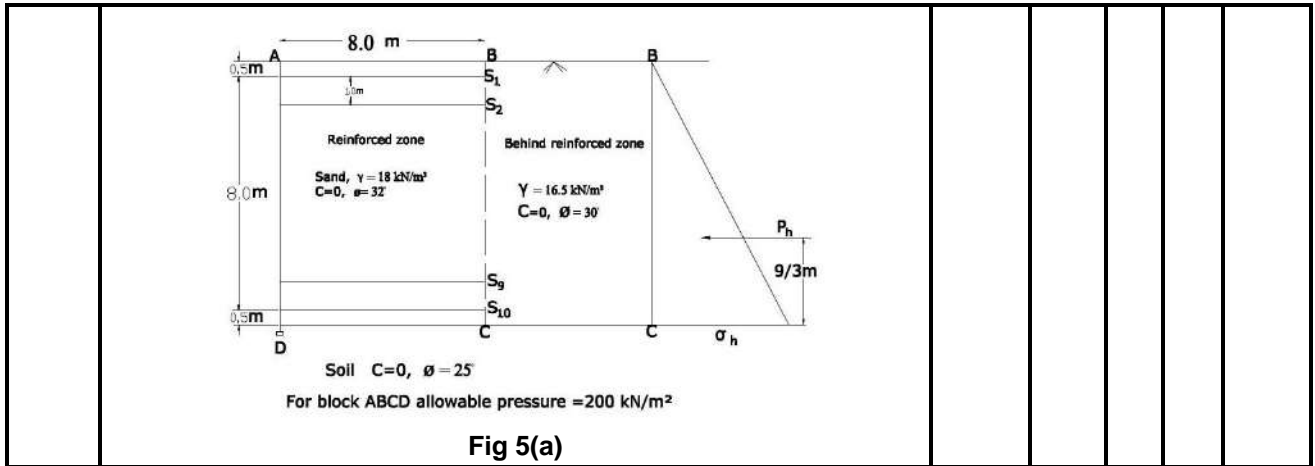

5b	<p>Site A and Site B are two sites located at a distance 20km and 30km respectively from a city. Below table gives the details for both sites.</p> <p>i) What criteria to be considered while selecting a landfill site?</p> <p>ii) Compare the score of both sites and suggest which site is best suited for constructing a landfill.</p>	12	CO7	L4	2	2.1.2																																												
<table border="1" style="width: 100%; border-collapse: collapse;"> <thead> <tr> <th rowspan="2">Parameters</th> <th rowspan="2">weightage</th> <th colspan="4">Sensitivity indices</th> <th rowspan="2">SiteA</th> <th rowspan="2">Site B</th> </tr> <tr> <th>0.25</th> <th>0.50</th> <th>0.75</th> <th>1.00</th> </tr> </thead> <tbody> <tr> <td>Distance (km)</td> <td>100</td> <td>10</td> <td>20</td> <td>30</td> <td>40</td> <td>20</td> <td>30</td> </tr> <tr> <td>Population within 500m</td> <td>300</td> <td>200</td> <td>400</td> <td>600</td> <td>800</td> <td>600</td> <td>400</td> </tr> <tr> <td>Depth to GW (m)</td> <td>400</td> <td>40</td> <td>30</td> <td>20</td> <td>10</td> <td>20</td> <td>40</td> </tr> <tr> <td>Soil type</td> <td>200</td> <td>Clay</td> <td>Silt</td> <td>Sand</td> <td>Gravel</td> <td>Silt</td> <td>gravel</td> </tr> </tbody> </table>		Parameters	weightage	Sensitivity indices				SiteA	Site B	0.25	0.50	0.75	1.00	Distance (km)	100	10	20	30	40	20	30	Population within 500m	300	200	400	600	800	600	400	Depth to GW (m)	400	40	30	20	10	20	40	Soil type	200	Clay	Silt	Sand	Gravel	Silt	gravel					
Parameters	weightage			Sensitivity indices						SiteA	Site B																																							
		0.25	0.50	0.75	1.00																																													
Distance (km)	100	10	20	30	40	20	30																																											
Population within 500m	300	200	400	600	800	600	400																																											
Depth to GW (m)	400	40	30	20	10	20	40																																											
Soil type	200	Clay	Silt	Sand	Gravel	Silt	gravel																																											

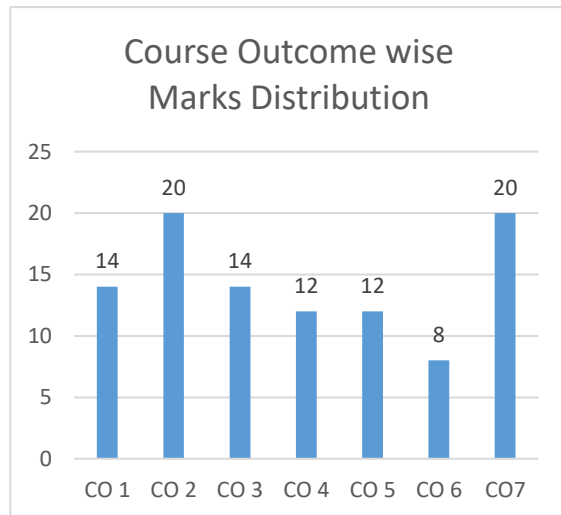
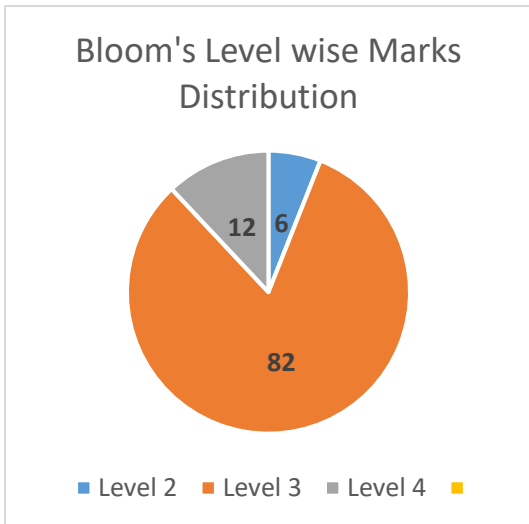

**BL – Bloom’s Taxonomy Levels (1- Remembering, 2- Understanding, 3 – Applying, 4 – Analysing, 5 – Evaluating, 6 - Creating)**

**CO – Course Outcomes**

**PO – Program Outcomes; PI Code – Performance Indicator Code**

# Course Name: Construction Project Management

## Course Outcomes (CO):

1. Determine the inter-relationships of construction drawings and specifications and their working in construction engineering and management.
2. Develop Work Breakdown Structure (WBS) for various types of buildings.
3. Construct a construction project schedule by combining the WBS, duration and networking methods.
4. Develop a safety protocol for various construction projects depending on the site conditions in alignment with SP 70 2001 manual.
5. Analyse the various site conditions on a construction project and select construction equipment best suited for those conditions.

**Model Question Paper**  
**Total Duration (H:M): 3:00**  
**Course: Construction Project Management**  
**Maximum Marks :100**

Q.No	Questions	Marks	CO	BL	PI
1	<p>Analyze the given drawing to determine the scope of work and sequence the activities in order of their construction.</p>	20	CO1	L3	2.1.2



Q.No	Questions	Marks	CO	BL	PI																														
2	There is an immediate need for the construction of a small concrete bridge between two villages before the monsoon season arrives, as an assistant engineer in the PWD, your preceding officer has asked to create a third-level WBS accounting for all the major milestones to be achieved to aid the estimation process.	20	CO2	L3	3.2.1																														
3	<p>The following data is for a construction of a commercial complex which your company is about to build. The activities, durations and the interdependencies were finalized in the planning meeting. Analyze and determine the earliest duration to execute the project. Also, determine if there are additional days, other than the planned durations for the non-critical activities.</p> <table border="1"> <thead> <tr> <th>Activity</th> <th>Duration (Weeks)</th> <th>Interdependency</th> </tr> </thead> <tbody> <tr> <td>Site Clearance</td> <td>4</td> <td>-</td> </tr> <tr> <td>Surveying</td> <td>2</td> <td>Site Clearance</td> </tr> <tr> <td>Excavation</td> <td>4</td> <td>Site Clearance, Surveying,</td> </tr> <tr> <td>Foundation</td> <td>5</td> <td>Excavation</td> </tr> <tr> <td>Superstructure</td> <td>15</td> <td>Foundation</td> </tr> <tr> <td>Plastering</td> <td>4</td> <td>Superstructure</td> </tr> <tr> <td>Painting</td> <td>6</td> <td>Superstructure, Plastering</td> </tr> <tr> <td>Flooring</td> <td>4</td> <td>Plastering, Flooring</td> </tr> <tr> <td>Clean up</td> <td>2</td> <td>Plastering, Painting, Flooring.</td> </tr> </tbody> </table>	Activity	Duration (Weeks)	Interdependency	Site Clearance	4	-	Surveying	2	Site Clearance	Excavation	4	Site Clearance, Surveying,	Foundation	5	Excavation	Superstructure	15	Foundation	Plastering	4	Superstructure	Painting	6	Superstructure, Plastering	Flooring	4	Plastering, Flooring	Clean up	2	Plastering, Painting, Flooring.	20	CO3	L3	2.2.3
Activity	Duration (Weeks)	Interdependency																																	
Site Clearance	4	-																																	
Surveying	2	Site Clearance																																	
Excavation	4	Site Clearance, Surveying,																																	
Foundation	5	Excavation																																	
Superstructure	15	Foundation																																	
Plastering	4	Superstructure																																	
Painting	6	Superstructure, Plastering																																	
Flooring	4	Plastering, Flooring																																	
Clean up	2	Plastering, Painting, Flooring.																																	
4	<p>Develop a detailed safety protocol in accordance with SP 70 (Handbook on Construction safety practices) for the following projects:</p> <ol style="list-style-type: none"> <li>Residential Apartment Complex</li> <li>Highway Construction</li> </ol>	20	CO4	L3	2.2.3																														
5	<p>An electrical sub-station is to be built on a 7 acres of land. The following is the scope of work to be completed by your company. The project is to be completed in 4 months.</p> <ol style="list-style-type: none"> <li>Clearing of vegetation on site, which includes trees, shrubs and grass.</li> <li>Removing of top 1 meter soil and hauling it off to a dump site located 8 KMs from the worksite.</li> <li>Compacting the natural ground for 94 % Proctor Density.</li> <li>Placing of aggregates to the specified level as mentioned in the drawing.</li> <li>Compacting the placed aggregates for Modified Proctor Density of 98 %.</li> <li>Excavating for 85 piers of specified diameter.</li> <li>Placing Concrete in the piers.</li> <li>Asphalt of 6 inches over the aggregate base for the entire sub-station.</li> <li>Machine control is to be used for excavation and aggregate placement.</li> </ol> <p>Analyze the scope of the project and select at least two types of construction equipment to be used for this project. Compare and finalize the best fit.</p>	20	CO5	L4	2.2.3																														

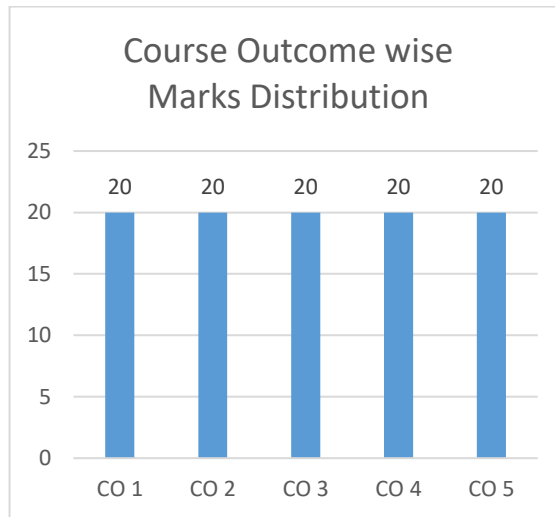
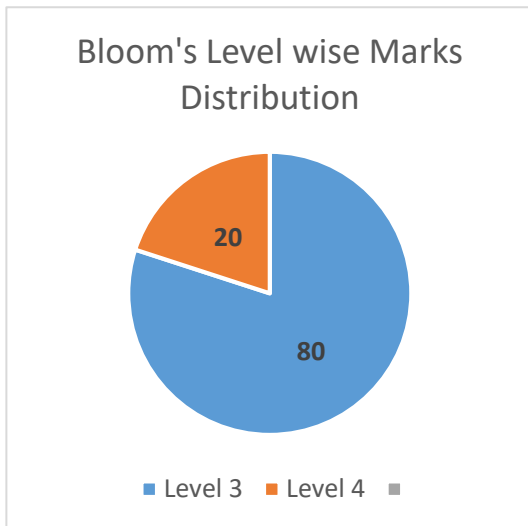

**BL – Bloom's Taxonomy Levels (1- Remembering, 2- Understanding, 3 – Applying, 4 – Analysing, 5 – Evaluating, 6 - Creating)**

**CO – Course Outcomes**

**PO – Program Outcomes; PI Code – Performance Indicator Code**

## Course Name: Advanced Project Management

### Course Outcomes (CO):

1. Assess the importance of monitoring and control phase during the execution of a construction project.
2. Combine estimating and scheduling and develop a cost loaded schedule which will combine both cost and time aspects into one cost loaded schedule.
3. Develop earned value reports to know the progress of the project at any instant of the project duration.
4. Evaluate the various bidding strategies employed in construction.
5. Conduct risk analysis to determine the probable risks involved and place appropriate mitigation measures in place.

**Model Question Paper**  
**Total Duration (H:M): 3:00**  
**Course: Advanced Project management**  
**Maximum Marks :100**

Q.No	Questions	Marks	CO	BL	PI															
1	<p>The following is the planned crew and quantity for the excavation activity. The scheduled work days is 6 days. The planned quantity is 3000 Cubic meters. Determine the planned total cost and unit cost for this activity.</p> <table border="1" style="width: 100%; border-collapse: collapse;"> <thead> <tr> <th>Labor Force Required</th> <th>Total Number</th> <th>Per Day Rates</th> </tr> </thead> <tbody> <tr> <td>Back Hoes</td> <td style="text-align: center;">07</td> <td style="text-align: center;">₹ 1000/day</td> </tr> <tr> <td>Operators</td> <td style="text-align: center;">07</td> <td style="text-align: center;">₹ 550/day</td> </tr> <tr> <td>Dump Trucks</td> <td style="text-align: center;">10</td> <td style="text-align: center;">₹ 600/day</td> </tr> <tr> <td>Dump Truck Drivers</td> <td style="text-align: center;">10</td> <td style="text-align: center;">₹ 350/day</td> </tr> </tbody> </table> <p>After 3 days, the following is the report generated from the site.</p> <p>Amount of work done: 1200 cubic meters. The crew worked for 8 hours/day for all the 3 days. Determine the cost that was spent for these 3 days. Comment on the productivity of the crew. Calculate the cost required to complete the work in the remaining 3 days. Analyze the given situation and determine whether additional crew is a better option compared to over-time for the existing crew.</p>	Labor Force Required	Total Number	Per Day Rates	Back Hoes	07	₹ 1000/day	Operators	07	₹ 550/day	Dump Trucks	10	₹ 600/day	Dump Truck Drivers	10	₹ 350/day	20	CO1	L4	2.2.1
Labor Force Required	Total Number	Per Day Rates																		
Back Hoes	07	₹ 1000/day																		
Operators	07	₹ 550/day																		
Dump Trucks	10	₹ 600/day																		
Dump Truck Drivers	10	₹ 350/day																		
2	<p>A typical small house construction project consists of the following operations along with the time set for its completion.</p> <table border="1" style="width: 100%; border-collapse: collapse;"> <thead> <tr> <th>Operation (Activities)</th> <th>Time (in days)</th> <th>Cost (in Rupees)</th> </tr> </thead> <tbody> <tr> <td>Survey, design and Layout</td> <td style="text-align: center;">6</td> <td style="text-align: center;">10000</td> </tr> <tr> <td>Construction of foundation</td> <td style="text-align: center;">5</td> <td style="text-align: center;">26000</td> </tr> </tbody> </table>	Operation (Activities)	Time (in days)	Cost (in Rupees)	Survey, design and Layout	6	10000	Construction of foundation	5	26000	20	CO2	L4	13.1.3						
Operation (Activities)	Time (in days)	Cost (in Rupees)																		
Survey, design and Layout	6	10000																		
Construction of foundation	5	26000																		

Q.No	Questions	Marks	CO	BL	PI																																										
	<table border="1"> <tr> <td>Construction of Superstructure</td> <td>11</td> <td>80000</td> </tr> <tr> <td>Roofing</td> <td>5</td> <td>34000</td> </tr> <tr> <td>Fixing door and window frames</td> <td>3</td> <td>16000</td> </tr> <tr> <td>Plumbing and Drainage</td> <td>4</td> <td>12000</td> </tr> <tr> <td>Electric Fitting</td> <td>4</td> <td>19000</td> </tr> <tr> <td>Plastering</td> <td>4</td> <td>7000</td> </tr> <tr> <td>Flooring</td> <td>4</td> <td>32000</td> </tr> <tr> <td>Carpentry work</td> <td>2</td> <td>10000</td> </tr> <tr> <td>Painting</td> <td>3</td> <td>8000</td> </tr> </table> <p>The project starts on Monday 16<sup>th</sup> November 2018. Assume 5 days-work week. The following data was collected from the job site.</p> <table border="1"> <thead> <tr> <th>Operation</th> <th>Percentage Complete</th> <th>Actual Cost (in Rupees)</th> </tr> </thead> <tbody> <tr> <td>Survey, design and Layout</td> <td>100 %</td> <td>11600</td> </tr> <tr> <td>Construction of foundation</td> <td>100 %</td> <td>25200</td> </tr> <tr> <td>Construction of Superstructure</td> <td>80 %</td> <td>76000</td> </tr> <tr> <td>Roofing</td> <td>25 %</td> <td>12000</td> </tr> </tbody> </table> <p>At present the data date is Friday, 11-12-2018.</p> <ol style="list-style-type: none"> <li>Determine the total duration of the project. State any assumptions you make.</li> <li>Compile PV (Planned Value), EV (Earned Value) and AC (Actual Cost) from the data provided.</li> <li>Analyze the status of the project (using EVA) and create a status report. Comment on the forecast of the project.</li> </ol>	Construction of Superstructure	11	80000	Roofing	5	34000	Fixing door and window frames	3	16000	Plumbing and Drainage	4	12000	Electric Fitting	4	19000	Plastering	4	7000	Flooring	4	32000	Carpentry work	2	10000	Painting	3	8000	Operation	Percentage Complete	Actual Cost (in Rupees)	Survey, design and Layout	100 %	11600	Construction of foundation	100 %	25200	Construction of Superstructure	80 %	76000	Roofing	25 %	12000				
Construction of Superstructure	11	80000																																													
Roofing	5	34000																																													
Fixing door and window frames	3	16000																																													
Plumbing and Drainage	4	12000																																													
Electric Fitting	4	19000																																													
Plastering	4	7000																																													
Flooring	4	32000																																													
Carpentry work	2	10000																																													
Painting	3	8000																																													
Operation	Percentage Complete	Actual Cost (in Rupees)																																													
Survey, design and Layout	100 %	11600																																													
Construction of foundation	100 %	25200																																													
Construction of Superstructure	80 %	76000																																													
Roofing	25 %	12000																																													
3a	<p>A project consists of 8 activities from A to F. The following is the progress report sent to you from the field after 2 months. The project was planned to be completed till activity D after 2 months. Analyse the project. Also comment on the status of each individual activity in terms of profit/loss.</p> <table border="1"> <thead> <tr> <th>S. No.</th> <th>Activity</th> <th>Planned Value</th> <th>Actual Cost</th> <th>Percentage Complete</th> </tr> </thead> <tbody> <tr> <td>1</td> <td>A</td> <td>10000</td> <td>9500</td> <td>100%</td> </tr> <tr> <td>2</td> <td>B</td> <td>25000</td> <td>26300</td> <td>100%</td> </tr> <tr> <td>3</td> <td>C</td> <td>32000</td> <td>35000</td> <td>96%</td> </tr> <tr> <td>4</td> <td>D</td> <td>28000</td> <td>17000</td> <td>72%</td> </tr> <tr> <td>5</td> <td>E</td> <td>56000</td> <td>30000</td> <td>46%</td> </tr> </tbody> </table>	S. No.	Activity	Planned Value	Actual Cost	Percentage Complete	1	A	10000	9500	100%	2	B	25000	26300	100%	3	C	32000	35000	96%	4	D	28000	17000	72%	5	E	56000	30000	46%	20	CO3	L3	11.3.1												
S. No.	Activity	Planned Value	Actual Cost	Percentage Complete																																											
1	A	10000	9500	100%																																											
2	B	25000	26300	100%																																											
3	C	32000	35000	96%																																											
4	D	28000	17000	72%																																											
5	E	56000	30000	46%																																											

Q.No	Questions					Marks	CO	BL	PI
	6	F	87000	24000	34%				
	7	G	96000						
	8	H	68000						
4a	There is a call for tender for construction of stadium in your city, only few reputed private construction companies have been asked to participate in the tender by the governing body, your company is one of them. Your boss asks you to prepare the necessary document which is required for the tendering work for the construction of stadium.					12	CO4	L2	11.3.1
4b	Discuss the different type of bidding models					08	CO4	L2	1.3.1
5	Your company has just won a bid to construct an electrical sub-station over 5 acres of land which is covered with vegetation. The major activities of the project are site clearance, surveying, subgrade base, piers and bolts, control room, asphalt base, painting and clean-up. Evaluate the project and list all risks that could occur on this project. List the mitigation techniques to be placed to counter the identified risks.					20	CO5	L3	2.1.1

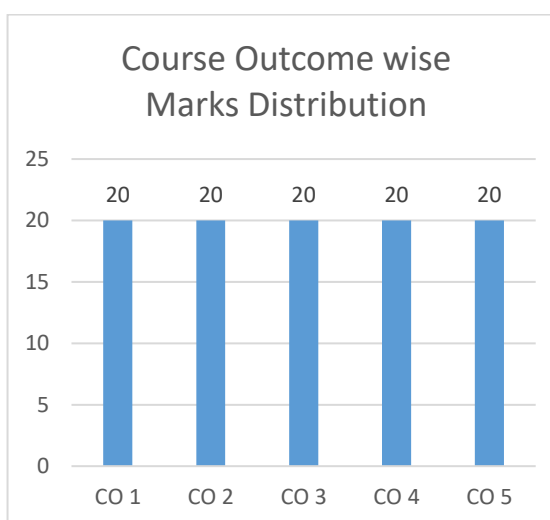
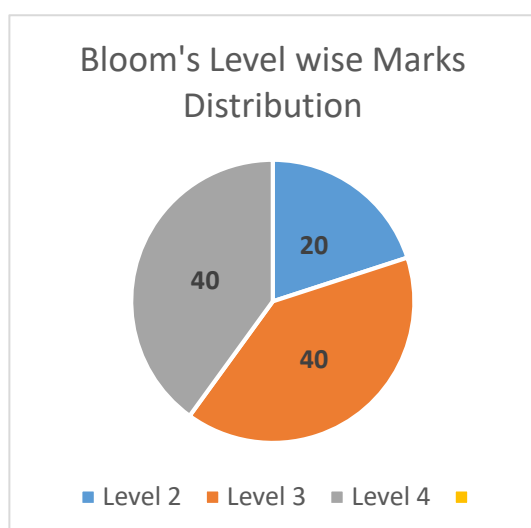

**BL – Bloom's Taxonomy Levels (1- Remembering, 2- Understanding, 3 – Applying, 4 – Analysing, 5 – Evaluating, 6 - Creating)**

**CO – Course Outcomes**

**PO – Program Outcomes; PI Code – Performance Indicator Code**

## Course Name: Design of RCC Structures

### Course Outcomes (CO):

1. Assess different design philosophies of R.C.C. structure and relative merits and demerits.
2. Analyze the structure for different methods under limit state design philosophy.
3. Estimate the moment carrying capacity and serviceability criteria of various structural elements.
4. Design the reinforced concrete sections such as beams, slabs, columns, footings and staircase.
5. Detail the bar bending scheme of the RCC structural elements.

**Model Question Paper**  
**Total Duration (H:M):3:00**  
**Course: Design of RCC Structures**  
**Maximum Marks :100**

Q.No	Questions	Marks	CO	BL	PI
1(a)	What are the different limit states of design? What are the merits of limit state design over other philosophies?	10	2	L2	1.3.1
1(b)	A RC beam 200mm wide and 500mm deep is reinforced with 3nos of 16mm dia bars. Find moment of resistance of beam. Effective span is 5m. If effective cover is 40mm find safe working load as well as super imposed load. Use M25 grade concrete and Fe500 grade steel.	10	3	L3	1.3.1
2(a)	Derive the stress block parameters for compressive force $C_u$ and Tensile force $T_u$ using limit state method of design.	5	1	L2	1.3.1
2(b)	A singly reinforced rectangular section of breadth 200mm and effective depth 400mm is made up of concrete of M20 grade and steel of Fe500 grade. Find out following <ol style="list-style-type: none"> <li>1. Calculate maximum moment of resistance that a given section can offer and also what is corresponding area of steel.</li> <li>2. Find moment of resistance and area of steel if depth of N.A. is restricted to <math>0.3d</math>.</li> <li>3. If c/s is reinforced with 4% of c/s size of beam find <math>X_u</math> for steel to fail and also moment of resistance at that instance.</li> <li>4. Check whether given c/s can withstand an ultimate B.M. of 100kNm. If not suggest alternate solution.</li> </ol>	15	3	L4	1.3.1
3	A Room is having clear dimensions of 3m x 6m. The superimposed live load on slab is $10 \text{ kN/m}^2$ , at service state. The slab is simply supported on all the four sides on a wall of 300mm thickness. The corners are held down. Decide whether the slab is designed as one way slab or two way	20	4	L3	2.3.1

Q.No	Questions	Marks	CO	BL	PI
	slab giving proper justifications. Design the slab using M-20 grade of concrete and Fe-415 grade of steel. Sketch the reinforcement details.				
4	A rectangular beam of effective span 6m needs to be designed. The superimposed load on the beam is 50kN/m. The c/s size of the beam is restricted to 300mmX600mm by the architect. List out different types of beams that can be provided under these circumstances. Design the beam which gives you optimal solution.	20	4	L4	2.3.1
5(a)	State and explain the basic assumptions made for design of columns under axial compression and uniaxial bending.	10	4	L2	1.3.1
5(b)	Design a rectangular R.C. footing for an R.C. column 230 mm x 450 mm carrying an axial load of 1500 kN. The S.B.C. of the soil is 150 kN/m <sup>2</sup> . Sketch the reinforcement details.	10	5	L3	2.3.1

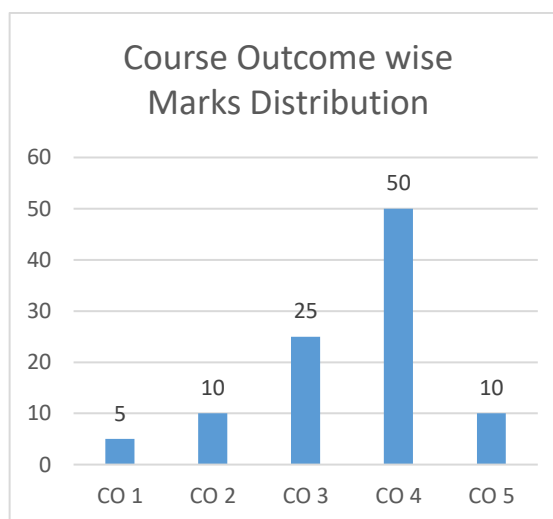
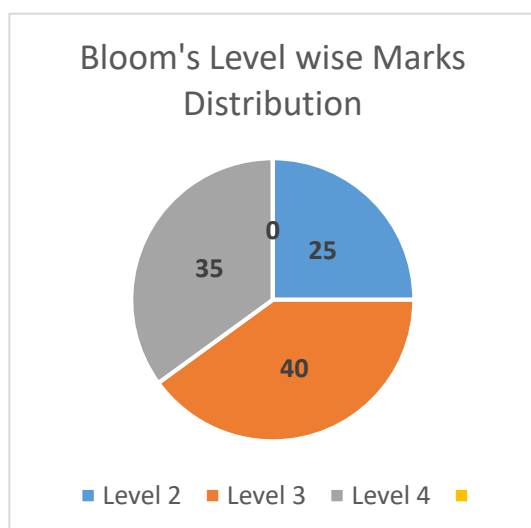

**BL – Bloom's Taxonomy Levels (1- Remembering, 2- Understanding, 3 – Applying, 4 – Analysing, 5 – Evaluating, 6 - Creating)**

**CO – Course Outcomes**

**PO – Program Outcomes; PI Code – Performance Indicator Code**

**Course Name: Environmental Engineering (15ECVC204)****Course Outcomes (CO):**

1. Discuss the impact of human activities on environment
2. Predict the population at the end of the design period and estimate the water demand of the city
3. Calculate the BHP of pump to lift the water from the source and convey to the treatment plant
4. Analyze the quality of water and design the treatment units required to meet BIS guidelines.
5. Calculate the capacity of storage reservoir required for the distribution of water
6. Estimate the quantity of sewage generated for different sewerage systems and design the sewer for different depths of flow to ensure self –cleansing velocity
7. Analyze the constituents of concern in domestic waste water and describe the appropriate processes for target pollutants to be removed.
8. Design the treatment process to treat the waste water to meet the desired limits
9. Explain the process of self-purification of the sources of disposal and determine the degree of treatment of sewage based on source of disposal of waste water

**Model Question Paper**  
**Total Duration (H:M):3:00**  
**Course: Environmental Engineering**  
**Maximum Marks: 100**

Q.No	Questions	Marks	CO	BL	PI														
1(a)	<p>Predict the population of the city in the year 2040 and also estimate the design demands of the water supply scheme. The census report is as follows:</p> <table border="1" style="margin-left: auto; margin-right: auto;"> <thead> <tr> <th>Census Year</th> <th>Population</th> </tr> </thead> <tbody> <tr> <td>1960</td> <td>31500</td> </tr> <tr> <td>1970</td> <td>37800</td> </tr> <tr> <td>1980</td> <td>51700</td> </tr> <tr> <td>1990</td> <td>57400</td> </tr> <tr> <td>2000</td> <td>59200</td> </tr> <tr> <td>2010</td> <td>67500</td> </tr> </tbody> </table> <p>Assume that the city is rapidly advancing.</p>	Census Year	Population	1960	31500	1970	37800	1980	51700	1990	57400	2000	59200	2010	67500	10	CO2	L3	1.1.1
Census Year	Population																		
1960	31500																		
1970	37800																		
1980	51700																		
1990	57400																		
2000	59200																		
2010	67500																		
1(b)	Discuss the impact of human activities on environment	06	CO1	L2	7.1.1														



Q.No	Questions	Marks	CO	BL	PI										
1 (c)	Discuss the criteria for selection of an indicator organisms	04	CO4	L2	1.2.1										
2 (a)	<p>For the water supply of a small town, water is required to be pumped from a tube well to an overhead tank. Work out the capacity of the pump. The data are given as below.</p> <table style="width: 100%; border-collapse: collapse;"> <tr> <td style="width: 60%;">Daily demand of water</td> <td style="text-align: right;">750 m<sup>3</sup></td> </tr> <tr> <td>Hours of pumping</td> <td style="text-align: right;">8</td> </tr> <tr> <td>Water table below ground level</td> <td style="text-align: right;">8 m</td> </tr> <tr> <td>Height of the tank above ground level</td> <td style="text-align: right;">14 m</td> </tr> <tr> <td>Loss of head in the pump and rising main</td> <td style="text-align: right;">1.75 m</td> </tr> </table>	Daily demand of water	750 m <sup>3</sup>	Hours of pumping	8	Water table below ground level	8 m	Height of the tank above ground level	14 m	Loss of head in the pump and rising main	1.75 m	10	CO3	L3	1.3.1
Daily demand of water	750 m <sup>3</sup>														
Hours of pumping	8														
Water table below ground level	8 m														
Height of the tank above ground level	14 m														
Loss of head in the pump and rising main	1.75 m														
2 (b)	Enumerate the impurities in ground water which should be taken into account in deciding the potability of a sample. State the effects when they exceed the prescribed BIS limits.	10	CO4	L2	1.2.1										
3 (a)	Design Clari-flocculation units to treat 15 MLD of water.	12	CO4	L3	2.1.2										
3(b)	<p>For the water supply of a small rural town with daily requirements of 225 m<sup>3</sup> of water, it is proposed to construct a distribution reservoir. The pattern of draw off is as follows</p> <table border="1" style="width: 100%; border-collapse: collapse;"> <tr> <td style="width: 40%;">7am--8 am</td> <td>30% of day's supply</td> </tr> <tr> <td>8 am---5 pm</td> <td>35% of day's supply</td> </tr> <tr> <td>5 pm –6.30pm</td> <td>30% of day's supply</td> </tr> <tr> <td>6.30pm ---7</td> <td>05% of day's supply</td> </tr> </table> <p>The pumping is done at a constant rate of 8 hours/day (8am- 4 pm). Determine the total capacity of service reservoir .The population of the town is 50,000.</p>	7am--8 am	30% of day's supply	8 am---5 pm	35% of day's supply	5 pm –6.30pm	30% of day's supply	6.30pm ---7	05% of day's supply	08	CO5	L3	1.3.1		
7am--8 am	30% of day's supply														
8 am---5 pm	35% of day's supply														
5 pm –6.30pm	30% of day's supply														
6.30pm ---7	05% of day's supply														
4(a)	Design a combined outfall sewer running 70 % full at maximum flow of sewage for a city having catchment area of 200 hectare, rainfall intensity 20 mm/hr all of which is runoff. Projected population of the city is 4 lakh. Water to the city is supplied from the water works at a rate of 250 lpcd. The sewer is to be laid at a slope of 1 in 450. Take N= 0.013.	8	CO6	L4	2.1.2										
4(b)	The following observation was made on a 3% dilution of sewage.	6	CO7	L3											

Q.No	Questions	Marks	CO	BL	PI
	DO of aerated water for dilution 3 mg/l DO of diluted sample after 5 day incubation 0.8 mg/l DO of original sample 0.6 mg/l Calculate BOD, Ultimate BOD and 3 days BOD at 37 ° C. Take $k = 0.23/d$				1.1.1
4( c)	Explain the working of a grit chamber with a neat sketch	6	CO7	L2	1.3.1
5(a)	Design ASP to treat settled sewage of 10 MLD having a BOD of 180 mg/l ,it is desired to produce a filter effluent having a BOD 20 mg/l	12	CO8	L4	2.1.2
5(b)	A city discharges 1500l/s of sewage into a stream whose minimum rate of flow is 6000l/s. The 5 day BOD for sewage is 200 mg/l and that of river is 1 mg/l .The DO content of stream is 90 % of the saturation DO. If the minimum DO to be maintained in the stream is 4.5 mg/l, determine the degree of sewage treatment required. Assume $K_D = 0.1/day$ and $K_R = 0.3/day$ .	8	CO9	L3	1.3.1

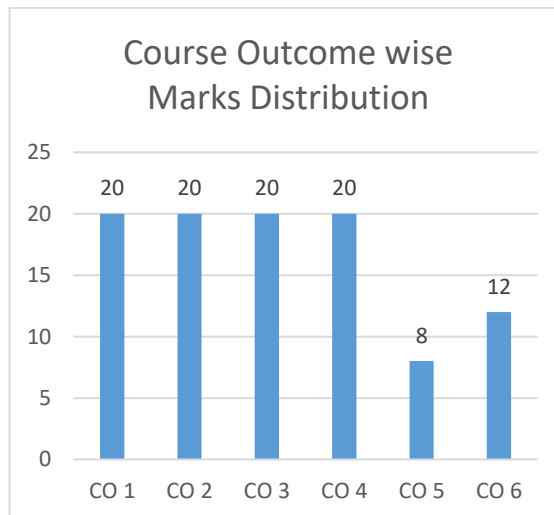
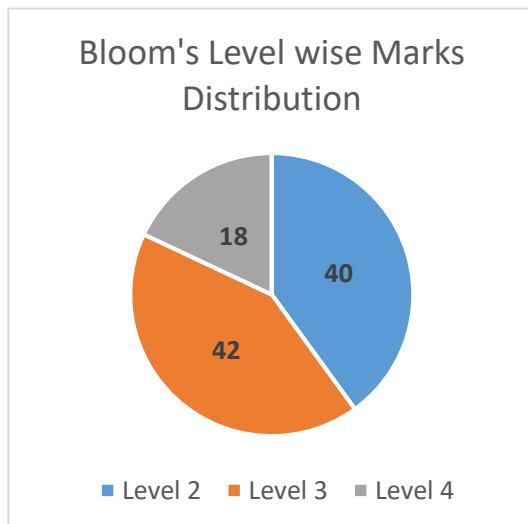

**BL – Bloom's Taxonomy Levels (1- Remembering, 2- Understanding, 3 – Applying, 4 – Analysing, 5 – Evaluating, 6 - Creating)**

**CO – Course Outcomes**

**PO – Program Outcomes; PI Code – Performance Indicator Code**

# Computer Science & Engineering

## Model Question Papers

### For Undergraduate Program

The model question papers are suggestive blueprints. The primary aim of these question papers is to bring clarity about the process of connecting questions to performance indicators and hence to course outcomes. Further, these question papers demonstrate how bloom's taxonomy can be used to understand the quality of question papers and their effectiveness in assessing higher order abilities. The structure of question papers, number of questions, choices given, time given for examination etc., can vary based on the practices of the University or college.

# Table of Contents

<b>Name of Course</b>	<b>Page No.</b>
1. Discrete Mathematical Structures	CSE1-CSE5
2. Data Structures and Algorithms	CSE6- CSE9
3. Computer Organization & Architecture	CSE10- CSE14
4. Machine Learning	CSE15- CSE18
5. Operating System	CSE19- CSE23
6. Data Mining and Analysis	CSE24- CSE29

## Course Name: Discrete Mathematical Structures

### Course Outcomes (CO):

1. Apply logic and rules of inference to draw a conclusion from a set of premises in a finite sequence of steps.
2. Apply principles of sets operations and functions.
3. Apply various operations on sets and represent them using Venn diagram.
4. Use the fundamental counting principles to determine the number of outcomes for a specified problem.
5. Develop the recurrence relation for the given problems
6. Discuss and differentiate the types of functions, relations and groups.

**Model Question Paper**  
**Total Duration (H: M): 3:00**  
**Course: Discrete Mathematical Structures**  
**Maximum Marks: 100**

Note: Answer Any two questions from UNIT I, UNIT II and one question from UNIT III

Q.No	Questions	Marks	CO	BL	PI
UNIT I					
1a	In asynchronous transfer mode (ATM), data are organized into cells of 53 bytes. Identify the range (number of ATM cells transmitted ) for the domain (minutes) set $M=\{1, 2, 3, 4, 5, 6\}$ if connection that transmits data at the rate of i) 128 kilobits per second ii) 300 kilobits per second iii) 1 megabit per second	10	CO2	L3	1.1.1
1b	Write the propositions for the following English statements. To use the wireless network in the airport you must pay the daily fee unless you are a subscriber to the service. Express your answer in terms of w: You can use the wireless network in the airport. d: You pay the daily fee. and s: You are a subscriber to the service.	5	CO 1	L3	1.1.1
1c	Let p,q and r be the propositions P: You have attended cultural audition. q: You miss the first minor exam. r: You will not get the make-up exam. Express each of these propositions as an English sentence i) $(p \rightarrow \neg r) \vee (q \rightarrow \neg r)$ ii) $(p \wedge q) \vee (\neg q \wedge r)$ iii) $\neg q \leftrightarrow r$	5	CO1	L2	1.1.1

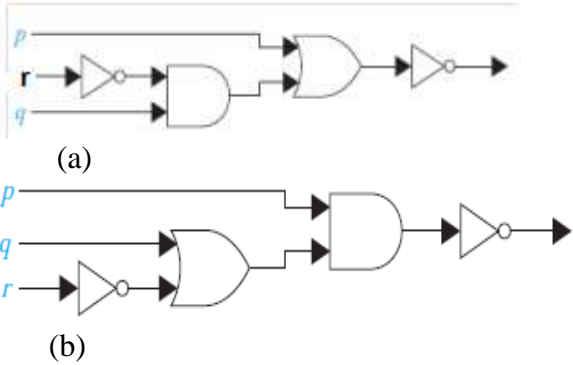
Q.No	Questions	Marks	CO	BL	PI
2a	Let A, B, and C be sets. Show that $\overline{A \cup (B \cap C)} = (\bar{C} \cup \bar{B}) \cap \bar{A}$	5	CO 2	L2	1.1.1
2b	Consider the following system specifications using the propositions “The message is scanned for viruses” or “The message was sent from an unknown system” “When a message is not sent from an unknown system it is not scanned for viruses.” “The message is scanned for viruses” Is the specification consistent? Justify your answer	5	CO 1	L3	1.1.1
2c	Consider the combinational circuit shown in below figure and answer the following.  <ol style="list-style-type: none"> <li>Find the output of combinational circuits (a) and (b).</li> <li>Write the simplified form of negation of the output.</li> <li>Assume appropriate p, q and r and express the output in English sentence.</li> </ol>	10	CO1	L3	1.1.1
3a	Let f, g, h be functions from $\mathbf{R} \rightarrow \mathbf{R}$ where $f(x)=x^2, g(x) =x+5$ and $h(x) =\sqrt{x^2 + 2}$ . Determine $((h \circ g) \circ f) (x)$ .	5	CO 2	L2	1.1.1
3b	Identify which of the following propositional statements are tautology using laws of equivalence. i) $[ p \vee q \vee (\neg p \wedge \neg q \wedge r ) ] \longleftrightarrow ( p \vee q \vee r )$ ii) $\neg (p \rightarrow q) \rightarrow \neg q$	10	CO 1	L3	1.1.1
3c	State whether the following statements are true or false i) Every infinite sets are countable ii) Every relation is not necessarily function iii) What time is it? is a proposition iv) Every bijective functions are inverse functions v) $(f \circ g)(a) = f(g(a))$ .	5	CO 2	L3	1.1.1
UNIT II					
4a	Suppose that at some future time every telephone in the world is assigned a number that contains a country code 1 to 3 digits long, that is, of the form X, XX, or XXX, followed by a 10-digit telephone	6	CO4	L3	1.1.1

Q.No	Questions	Marks	CO	BL	PI
	number of the form NXX-NXX-XXXX. How many different telephone numbers would be available worldwide under this numbering plan?				
b	How many positive integers between 100 and 999 inclusive i) are divisible by 7? ii) are not divisible by 4? iii) are divisible by 3 and 4? iv) are divisible by 3 or 4? v) are divisible by 3 but not by 4 and 7?	8	CO4	L3	1.1.1
c	For the relations $R_1=\{(a,b), (a,c), (b,d), (d,d)\}$ and $R_2=\{(a,a), (a,d), (b,a), (b,b), (c,e), (d,d), \}$ on sets $\{a,b,c,d,e\}$ to $\{a,b,c,d,e\}$ determine $R_2 \circ R_1$ . Represent the output relation using directed graph.	6	CO3	L2	1.1.1
5a	Consider the following relation $R=\{(1,1),(1,2),(1,3),(1,4), (2,2),(2,3),(2,4),(3,3),(3,4),(4,4)\}$ defined over the set $S=\{1,2,3,4\}$ i) Is $(S,R)$ is a Poset? Justify your answer. ii) Is $(S,R)$ Linearly ordered? Justify your answer. iii) Is $(S,R)$ Well-ordered? Justify your answer. iv) Identify the minimal, maximal, greatest and least elements v) Identify the lower bound and upper bound for the set $\{3\}$ and also find the least upper bound and greatest lower bound.	10	CO3	L3	1.1.1
b	In how many possible orders a student can answer 5 questions in the SEE exams considering the following conditions i) There are 3 units UNIT1, UNIT2 and UNIT3 consisting of 3, 3 and 2 questions respectively. ii) Student has to answer 2 questions from UNIT 1, 2 questions from UNIT 2 and one from UINIT 3	6	CO4	L2	1.1.1
c	In order to conduct the SEE examination, In how many ways seating arrangement can be made for 240 CS students and 240 EC students such that CS and EC students should sit alternatively.	4	CO4	L3	1.1.1
6a	School of Computer Science and Engineering is planning to create a Computer network lab of 15 computers. In how many ways every computer is connected to every other computer for each of the following assumptions. i) Every computer is implicitly connected to itself ii) Every computer is explicitly connected to itself iii) Every connection is one-way communication iv) Every connection is two-way communication	8	CO4	L3	1.1.1

Q.No	Questions	Marks	CO	BL	PI
b	Let R be the relation on the set of people with doctorates such that $(a, b) \in R$ if and only if ' $a$ ' was the thesis advisor of ' $b$ '. When is an ordered pair $(a, b)$ in $R^2$ ? When is an ordered pair $(a, b)$ in $R^n$ , when $n$ is a positive integer? (Assume that every person with a doctorate has a thesis advisor.)	8	CO3	L3	1.1.1
c	Let R1 and R2 be the "congruent modulo 3" and the "congruent modulo 4" relations, respectively, on the set of integers. That is, $R1 = \{(a, b) \mid a \equiv b \pmod{3}\}$ and $R2 = \{(a, b) \mid a \equiv b \pmod{4}\}$ . Find i) $R1 \cup R2$ . ii) $R1 \cap R2$ . iii) $R1 - R2$ . iv) $R2 - R1$ .	4	CO3	L2	1.1.1
UNIT III					
7a	A vending machine dispensing books of stamps accepts only one-dollar coins, \$1 bills, and \$5 bills. a) Find a recurrence relation for the number of ways to deposit $n$ dollars in the vending machine, where the order in which the coins and bills are deposited matters. b) What are the initial conditions? c) How many ways are there to deposit \$10 for a book of stamps?	6	CO5	L3	1.1.2
b	Solve these recurrence relations together with the initial conditions given. i. $a_n = 2a_{n-1}$ for $n \geq 1$ , $a_0 = 3$ ii. $a_n = a_{n-1}$ for $n \geq 1$ , $a_0 = 2$	6	CO5	L2	1.1.2
c	a) Find a recurrence relation for the number of steps needed to solve the Tower of Hanoi puzzle. b) Show how this recurrence relation can be solved using iteration.	8	CO5	L3	1.1.2
8a	i) Check whether the binary operation $*$ is commutative and associative on the set a) On $Z$ , where $a*b$ is $ab$ b) on $Z_+$ , where $a*b$ is $a+b+2$ ii) Prove or disprove the binary operation on $Z_+$ of $a*b = \text{GCD}(a,b)$ has the idempotent property.	8M	CO6	L3	1.1.1
b	Check whether set $Z$ with the binary operation of subtraction is a semi group.	6M	CO6	L2	1.1.1
c	Define – i) Group ii) Rings iii) Fields give one example for each with domain as set of positive integers.	6M	CO6	L2	1.1.1



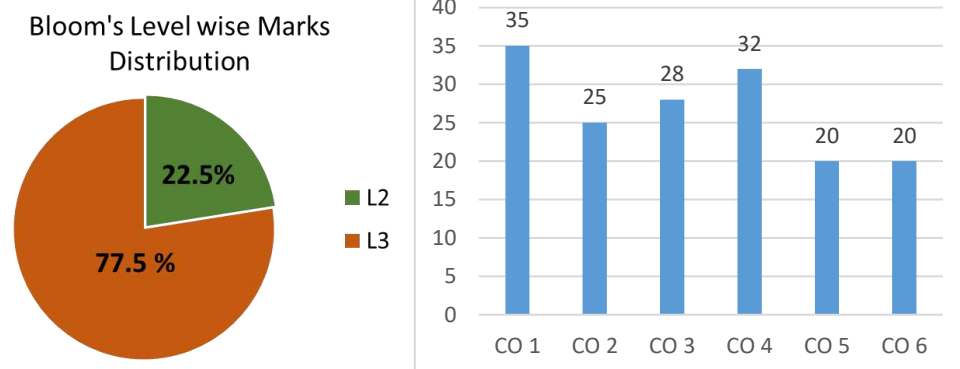

**BL – Bloom’s Taxonomy Levels (1- Remembering, 2- Understanding, 3 – Applying, 4 – Analysing, 5 – Evaluating, 6 - Creating)**

**CO – Course Outcomes**

**PO – Program Outcomes; PI Code – Performance Indicator Code**

## Course Name: Data Structures and Algorithms

### Course Outcomes (CO):

1. Discuss the C language features and analyze the differences between recursive and iterative programming structures
2. Analyze the role of data structures in structuring and manipulating data and implement them using array or list representation
3. Discuss the properties, operations, applications, strengths and weaknesses of the different data structures and their effect on algorithms
4. Analyze, interpret and compare various sorting, searching and graph algorithms and perform efficiency analysis
5. Discuss the file structures and storage management for efficient access of data

**Model Question Paper**  
**Total Duration (H:M): 3:00**  
**Course: Data Structures and Algorithms**  
**Maximum Marks: 100**

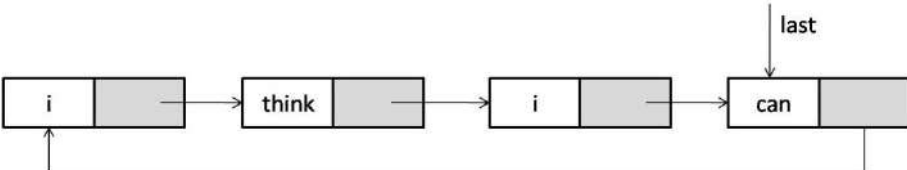
Q.No	Questions	Marks	CO	BL	PI
1(a)	Suppose we wish to search a linked list of length $n$ , where each element contains a key $k$ long with a hash function $h(k)$ . Each key is a long character string. How might we take advantage of the hash values when searching the list for an element with a given key?	4	CO3	L3	1.4.1
1(b)	With the help of suitable code snippets, Prove That: "Queue is NO more exactly a First In First Out data structure"	6	CO2	L2	1.4.1
1(c)	Using state space tree prove that: <ul style="list-style-type: none"> <li>• There is no solution for a 2 queen problem</li> <li>• There are multiple solutions for a 4 queen problem</li> </ul>	10	CO1	L2	1.4.1
2(a)	Differentiate between Structures and Unions with suitable code snippets.	4	CO1	L3	1.4.1
2(b)	A linear probing has a hash function of the form: $h(k, i) = (h'(k) + i) \bmod m$ and a quadratic probing has a hash function of the form: $h(k, i) = (h'(k) + c_1 i + c_2 i^2) \bmod m$ . Linear probing suffers from a problem known as primary clustering and quadratic probing from secondary clustering. Discuss.	6	CO3	L3	1.4.1
2(c)	Consider the circular list given below with string data:  Write a function which will display the output in following fashion: <i>i think i can</i> <i>think i can</i>	10	CO2	L3	1.4.1

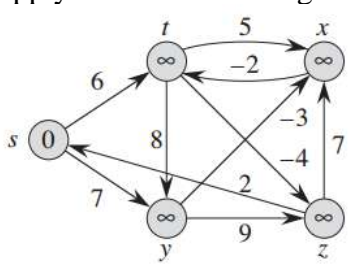
Q.No	Questions	Marks	CO	BL	PI
	<p><i>i can</i> <i>can</i></p> <p>At each line, the function should display data from all the nodes present. After printing each line, an appropriate node has to be deleted. After printing the last line, “last” pointer should be holding the NULL value.</p>				
3(a)	Write a program to print the nth node from end from a singly linked list.	4	CO2	L3	1.4.1
3(b)	<p>Complete the function described below: Function Name: summon Input Params: base address of string Return Type: base address of summoned string Description: A magician wants to generate summoning charms. For input string “firebolt”, the function should produce “summon firebolt”. Do not use any inbuilt string handling functions.</p>	6	CO1	L3	1.4.1
3(c)	<p>Write the modules to implement the following using Stack data structure:</p> <ul style="list-style-type: none"> <li>• Check if the given string is palindrome</li> <li>• Sort the given set of integers</li> </ul>	10	CO3	L3	1.4.1
4(a)	<p>You have been invited to a post-exam party.</p> <p>i) You walk in and shake everyone’s hand. As the number of attendees N increases, what is the order of growth to shake everyone’s hand? Justify.</p> <p>ii) You meet everyone else and during each meeting, you talk about everyone else in the room. To what efficiency class does this belong to? Justify.</p>	4	CO3	L4	1.1.2
4(b)	<p>Create a AVL Tree for: 50, 60, 80, 30, 20, 40, 70</p> <p>Can you perform the three tree traversals on AVL tree? Justify your answer.</p>	6	CO3	L3	1.4.1
4(c)	<p>Apply Bellman-Ford Algorithm on the given graph.</p>  <p>How is Bellman-Ford different from Dijkstra’s Algorithm? To what design technique does the algorithm belong to? Explain.</p>	10	CO4	L3	1.4.1
5(a)	Bring out the differences between Prim’s and Kruskal’s algorithm. Also compare with respect to efficiency analysis.	4	CO4	L2	1.4.1
5(b)	<p>Write a algorithm for given below description: ALGORITHM CountLeafNodes(T) // Recursively counts the number of leaf nodes in the tree T</p>	6	CO3	L3	1.4.1

Q.No	Questions	Marks	CO	BL	PI
5(c)	Apply Quick Sort on the following: QUICKSORT Write the efficiency analysis of quick sort (Best, Worst, and Average).	10	CO4	L3	1.1.2
6(a)	Write the algorithm design technique for the given below algorithms/problems: i) N-Queen's Problem ii) Binary Search iii) Insertion Sort iv) AVL Trees v) Heap Sort vi) Hashing vii) Boyer-Moore viii) Breadth First Search	4	CO4	L2	1.4.1
6(b)	A DNA sequence consists of a text on the alphabet {A, C, G, T} and the gene or gene segment is the pattern. For the pattern for chromosome-10: TCCTATTCTT construct the following tables: i) $\pi$ - table ii) Bad Symbol Shift Table	6	CO4	L3	1.4.1
6(c)	Write a function to delete a node from a Binary Search Tree. Suitably comment the code explaining each of the cases.	10	CO3	L3	1.4.1
7(a)	What are indexed sequential files?	4	CO5	L1	1.4.1
7(b)	Explain fseek( ) API with help of a C suitable program. Explain each of the parameter it takes in detail.	6	CO5	L3	1.4.1
7(c)	A file consists of binary data. Write a program to read and count the number of 0's and 1's in it. Write the individual count in a separate file. Also find the size of the file.	10	CO5	L3	1.4.1
8(a)	What do you mean by storage release?	4	CO5	L1	1.4.1
8(b)	Differentiate between the fixed block and variable block storage management.	6	CO5	L2	1.4.1
8(c)	With a help of a suitable program explain the concept of Bit Maps and how they can be used as an efficient storage means.	10	CO5	L3	1.4.1

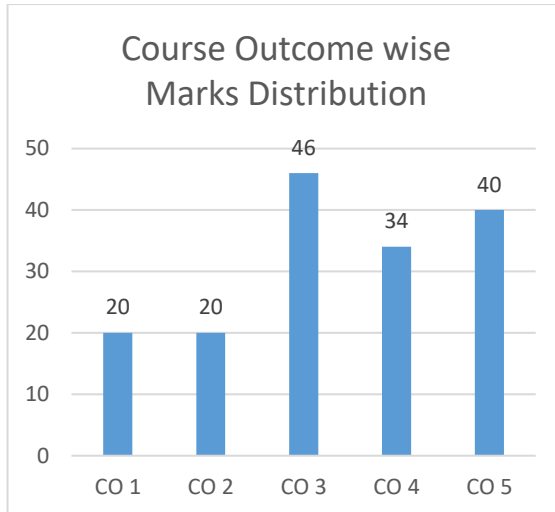
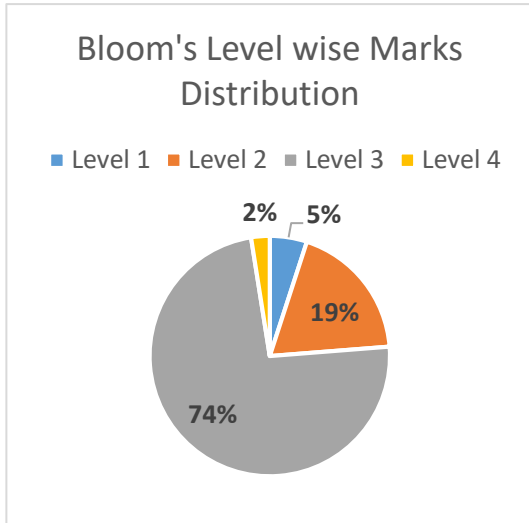

**BL – Bloom’s Taxonomy Levels (1- Remembering, 2- Understanding, 3 – Applying, 4 – Analysing, 5 – Evaluating, 6 - Creating)**

**CO – Course Outcomes**

**PO – Program Outcomes; PI Code – Performance Indicator Code**

## Course Name: Computer Organization & Architecture

### Course Outcomes (COs):

At the end of the course the student should be able to:

1. Design combinational and sequential circuits using digital components.
2. Analyze different types of communication between processor and peripherals.
3. Design memory units for given specifications.
4. Describe the architectures of various processors.
5. Analyze the performance of pipelined architecture in a processor.

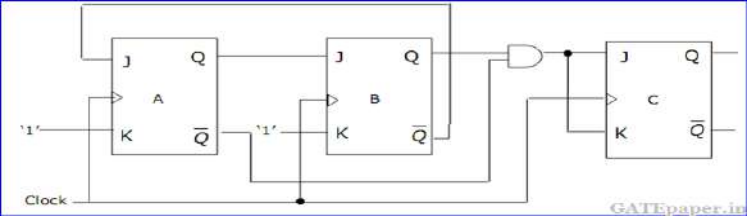
Model Question Paper for End Semester Examination					
Course Code:		Course Title: Computer Organization and Architecture			
Duration: 3 hrs		Max. Marks: 100			
Note: Answer five questions; any two full questions from each unit-I and unit-II and one full question from unit-III					
Unit-I					
Q.No	Questions	Marks	CO	PI Code	B L
1 a	Implement the Boolean function $F(A,B,C,D)=BC+ABC+A'C'D$ using only a single 8X1 Multiplexer where signals A,B,C,D and D' represent the inputs.	6	CO1	1.4.4	L2
b	<p>The circuit diagram of a synchronous counter is shown in the given figure. Determine the sequence of states of the counter assuming that the initial state is "000". Give your answer in a tabular form showing the present state QA, QB, QC, J-K inputs (JA, KA, JB, KB, JC, KC) and the next state QA+, QB+, QC+. From the table, determine the modulus of the counter.</p> 	6	CO1	1.4.4	L3
c	Consider the instruction Load R2,(R3). What control signals are generated in the datapath during the execution of this instruction. Justify your answer with proper reasoning.	8	CO2	1.4.4	L3
2 a	Realize a Boolean expression $f(w,x,y,z)=\sum m(1,2,6,7,8,9,11,13,14,15)$ using Multiplexer Tree structure. The first level should consist of two 4: 1 MUX with variables w and z on their select lines S1 and S0 respectively and second level should consist of single 2:1 MUX with variable y on the select lines	6	CO1	1.4.4	L2

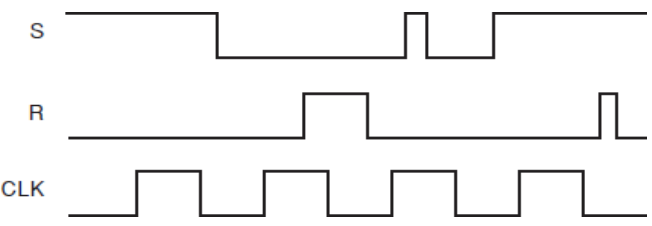
b	i. Explain the working of Gated SR latch. ii. What is forbidden state? iii. Determine the output waveform for a gated SR latch  	6	CO1	1.4.4	L3															
c	i. Load R4,(R3) ii. Store R4,(R3) For the above instructions draw the timing diagrams for synchronous bus operation	8	CO2	1.4.4	L3															
3 a	Explain Hardwired Control unit.	6	CO2	1.4.4	L2															
b	Design , Simulate and implement a 4-bit Universal Shift Register for following operation  <table border="1" data-bbox="391 869 1050 1052"> <thead> <tr> <th>Sl.no</th> <th>Selection Bits</th> <th>Operation</th> </tr> </thead> <tbody> <tr> <td>1.</td> <td>00</td> <td>Circular Shift Right</td> </tr> <tr> <td>2.</td> <td>01</td> <td>Parallel Load</td> </tr> <tr> <td>3.</td> <td>10</td> <td>Circular Shift Left</td> </tr> <tr> <td>4.</td> <td>11</td> <td>Hold</td> </tr> </tbody> </table>	Sl.no	Selection Bits	Operation	1.	00	Circular Shift Right	2.	01	Parallel Load	3.	10	Circular Shift Left	4.	11	Hold	6	CO1	1.4.4	L3
Sl.no	Selection Bits	Operation																		
1.	00	Circular Shift Right																		
2.	01	Parallel Load																		
3.	10	Circular Shift Left																		
4.	11	Hold																		
c	There is a queue for exchange of old 500 rupees currency notes after demonetization, in the post office. But a single customer can exchange only upto Rs. 4000/- per day. What components are necessary to design a system which alerts the user on reaching the maximum count? Also design the system to automate the counting process.	8	CO1	2.1.2	L3															
<b>Unit-II</b>																				
4a	Explain the operational model of SIMD computers.	6	CO4	1.4.4	L2															
b	A 40 MHz processor was used to execute a benchmark program with the following instructions and clock cycle counts:	6	CO4	1.4.4	L3															
	<table border="1" data-bbox="438 1534 1029 1892"> <thead> <tr> <th>Instruction type</th> <th>Instruction count</th> <th>Clock cycle count</th> </tr> </thead> <tbody> <tr> <td>Integer arithmetic</td> <td>45000</td> <td>1</td> </tr> <tr> <td>Data transfer</td> <td>32000</td> <td>2</td> </tr> <tr> <td>Floating point</td> <td>15000</td> <td>2</td> </tr> <tr> <td>Control transfer</td> <td>8000</td> <td>2</td> </tr> </tbody> </table> <p>Determine the effective CPI, MIPS rate and execution time for this program.</p>	Instruction type	Instruction count	Clock cycle count	Integer arithmetic	45000	1	Data transfer	32000	2	Floating point	15000	2	Control transfer	8000	2				
Instruction type	Instruction count	Clock cycle count																		
Integer arithmetic	45000	1																		
Data transfer	32000	2																		
Floating point	15000	2																		
Control transfer	8000	2																		

c	Consider a main memory built with SDRAM chips. Data are transferred in burst lengths of 8. Assume that 32 bits of data are transferred in parallel. If a 400-MHz clock is used, how much time does it take to transfer: (a) 32 bytes of data (b) 64 bytes of data What is the latency in each case?	8	CO3	1.4.4	L3																							
5a	Explain the pipelining process in VLIW processors.	6	CO4	1.4.4	L2																							
b	<p>The execution times (in seconds) of four programs on three computers are given below:</p> <table border="1" data-bbox="347 600 1086 891"> <thead> <tr> <th rowspan="2">Program</th> <th colspan="3">Execution Time (in seconds)</th> </tr> <tr> <th>Computer A</th> <th>Computer B</th> <th>Computer C</th> </tr> </thead> <tbody> <tr> <td>Program 1</td> <td>1</td> <td>10</td> <td>20</td> </tr> <tr> <td>Program 2</td> <td>1000</td> <td>100</td> <td>20</td> </tr> <tr> <td>Program 3</td> <td>500</td> <td>1000</td> <td>50</td> </tr> <tr> <td>Program 4</td> <td>100</td> <td>800</td> <td>100</td> </tr> </tbody> </table> <p>Assume that 100,000,000 instructions were executed in each of the four programs. Calculate the MIPS rating of each program on each of the three machines. Based on these ratings, can you draw a clear conclusion regarding the relative performance of the three computers? Rank them statistically.</p>	Program	Execution Time (in seconds)			Computer A	Computer B	Computer C	Program 1	1	10	20	Program 2	1000	100	20	Program 3	500	1000	50	Program 4	100	800	100	6	CO4	1.4.4	L3
Program	Execution Time (in seconds)																											
	Computer A	Computer B	Computer C																									
Program 1	1	10	20																									
Program 2	1000	100	20																									
Program 3	500	1000	50																									
Program 4	100	800	100																									
c	With neat figure show how a very small memory chip consisting of 16 words of 8 bits each is organized (16 X 8 organization). What is Double-Data-Rate SDRAM?	8	CO3	1.4.4	L3																							
6a	With a neat diagram of computer architecture explain the components involved in modern computer architecture.	6	CO4	1.4.4	L2																							
b	How does instruction set, compiler technology, CPU implementation and control and cache and memory hierarchy affect the CPU performance and justify the effects in terms of program length, clock rate and effective CPI	6	CO4	1.4.4	L3																							
c	Design a 8M x 32 size memory chip using memory chips of i. 512K x 16 ii. 256K x 8 Draw the diagrams showing appropriate connections for each of the above cases.	8	CO3	1.4.4	L3																							



Unit III					
7a	<p>With a neat diagram explain 5-stage pipeline organization.</p> <p>Consider the following instructions at the given addresses in the memory:            1000 ADD R4, R3, R2            1004 OR R7, R6, R5            1008 SUBTRACT R8, R7, R4</p> <p>Initially, registers R2 and R3 contain 4 and 8, respectively. Registers R5 and R6 contain 128 and 2 respectively. Assume that pipeline provides forwarding paths to the ALU from registers RY and RZ. The first instruction is fetched in clock cycle 1, and the remaining instructions are fetched in successive cycles. Draw a pipelined execution of these instructions assuming that processor is using operand forwarding. Describe the contents of registers, RY, and RZ in the pipeline during cycles 4 to 7.</p>	10	CO5	1.4.4	L3
b	<p>Explain with an example the different types of hazards. The following instructions are executed in pipelined architecture.</p> <p>SUBTRACT R4,R2,R3            BRANCH NEXT            OR R1, R2,#5            MUL R3,R4,R2            NEXT: LOAD R5,[R0]            ADD R6,R5,R2</p> <p>Identify hazards and suggest hardware or software approach to minimize the hazards.</p>	10	CO5	1.4.4	L3
8a	<p>Assume that 25% of dynamic count of instructions executed for a program is branch instructions. There are pipeline stalls due to data dependencies; static branch prediction is used with non-taken assumption.</p> <p>i. Determine execution time for two cases: when 30% of branches are taken, and when 80% of branches are taken.</p> <p>ii. Determine the speedup for one case relative to other. Express the speedup as percentage relative to 1.</p>	10	CO5	1.4.4	L3
b	<p>Explain the role of Dispatch unit to resolve Deadlock in scalar processor.</p>	10	CO5	1.4.4	L2

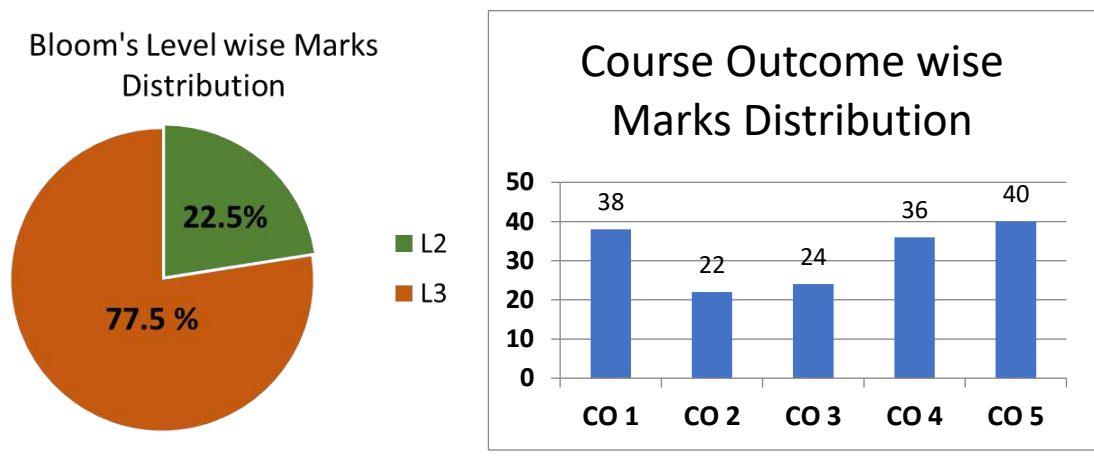

**BL – Bloom’s Taxonomy Levels (1- Remembering, 2- Understanding, 3 – Applying, 4 – Analysing, 5 – Evaluating, 6 - Creating)**

**CO – Course Outcomes**

**PO – Program Outcomes; PI Code – Performance Indicator Code**

**Competency addressed in the Course and corresponding Performance Indicators**

Competency	Performance Indicators
<b>1.4:</b> Demonstrate competence in computer science engineering knowledge	<b>1.4.4</b> Apply machine dependent/independent features to build system modules.
<b>2.1:</b> Demonstrate an ability to identify and characterize an engineering problem.	<b>2.1.2:</b> Identify processes, modules, variables, and parameters of computer based system to solve the problems.

Eg: 1.2.3: Represents Program Outcome „1“, Competency „2“ and Performance Indicators „3“.

## Course Name: Machine Learning

### Course Outcomes (CO):

1. Interpret and apply machine learning concepts.
2. Develop a machine learning model to extract knowledge from given data.
3. Apply a suitable supervised/un-supervised learning algorithm to solve a given problem.
4. Develop an autonomous system using reinforcement learning.
5. Evaluate various machine learning algorithms and build a solution for real-world applications.

**Model Question Paper**  
**Total Duration (H:M): 3:00**  
**Course: Machine Learning**  
**Maximum Marks: 100**

Q.No	Questions	Marks	CO	BL	PI
1a	A dealer has a warehouse that stores a variety of fruits and vegetables. When fruit is brought to the warehouse, various types of fruit may be mixed together. The dealer wants a model that will sort the fruit according to type. Justify with reasons how machine learning model is efficient compared to feature based classification technique.	10	CO1	L2	1.4.1
1b	Suppose you are only allowed to use binary logistic classifiers to solve a multi-class classification problem. Given a training set with 2 classes, this classifier can learn a model, which can then be used to classify a new test point to one of the 2 classes in the training set. You are now given a 6 class problem along with its training set, and have to use more than one binary logistic classifier to solve the problem, as mentioned before. Propose the following scheme - you will first train a binary logistic classifier for every pair of classes. Now, for a new test point, you will run it through each of these models, and the class which wins the maximum number of pairwise contests, is the predicted label for the test point. How many binary logistic classifiers will you need to solve the problem using your proposed scheme?	10	CO2	L3	2.1.3
2a	Describe the two error functions that are used for neural networks. Suppose we are training a neural network for binary classification, justify the type of error function which is suitable to solve the problem.	10	CO1	L3	1.4.1
2b	Why it is necessary to estimate the accuracy of hypothesis. Explain procedure to estimate difference in error between two learning methods.	10	CO3	L3	1.4.1
3a	Explain the effect of following factors in achieving global minima with gradient descent algorithm.	10	CO1	L3	2.1.3

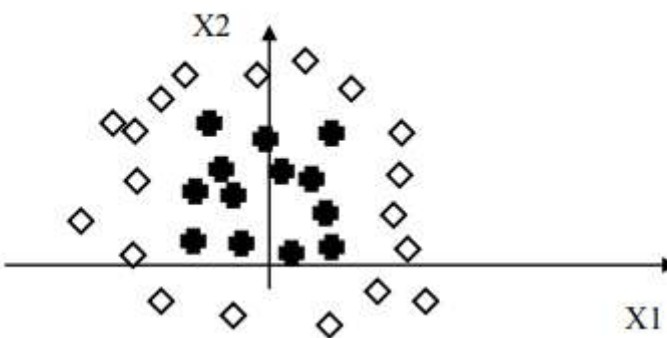
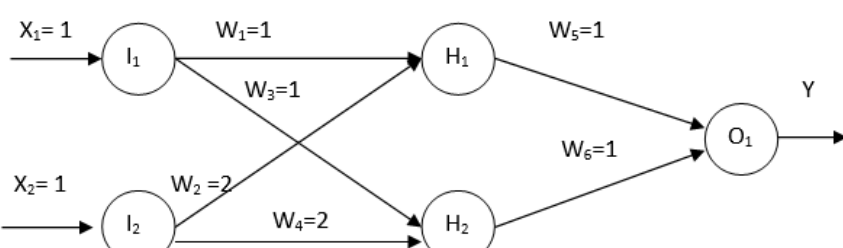
Q.No	Questions	Marks	CO	BL	PI
	<ul style="list-style-type: none"> <li>• Epochs</li> <li>• Learning rate</li> <li>• Weights of hypothesis (<math>\Theta_0</math> and <math>\Theta_1</math>)</li> </ul>				
3b	<p>Calculate the cost value of linear regression for the following dataset.  <math>X=[1,2,3,4,5]</math>  <math>Y=[3,6,7,11,15]</math>                      Slope of hypothesis (<math>\Theta_1</math>) = 7                      Constant/ intercept (<math>\Theta_0</math>)=5                      Epoch=3                      Learning rate (<math>\alpha</math>) = 0.5</p>	10	CO2	L3	2.1.3
4a	<p>Determine the Principal Components for the given 2-Dimensional dataset.  <math>(1, 2), (2, 4), (3, 6)</math>.</p>	10	CO3	L3	2.1.3
4b	<p>Suppose that we want to build a neural network that classifies two dimensional data (i.e., <math>X = [x_1, x_2]</math>) into two classes: diamonds and crosses. We have a set of training data that is plotted as follows:</p>  <p>Draw a network that can solve this classification problem. Justify your choice of the number of nodes and the architecture. Draw the decision boundary that your network can find on the diagram.</p>	10	CO1	L3	1.4.1
5a	<p>Consider the following Neural Network with <math>\alpha = 0.5</math>, <math>\eta=0.24</math>, desired output = 1 and sigmoid activation function.</p> <ol style="list-style-type: none"> <li>i. Perform one forward pass and calculate the error.</li> <li>ii. Calculate the updated weights for <math>w_5</math> and <math>w_6</math> using back-propagation.</li> </ol> 	10	CO3	L3	2.1.3

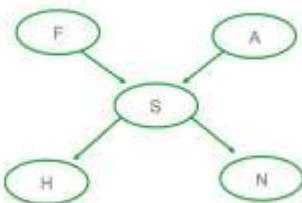
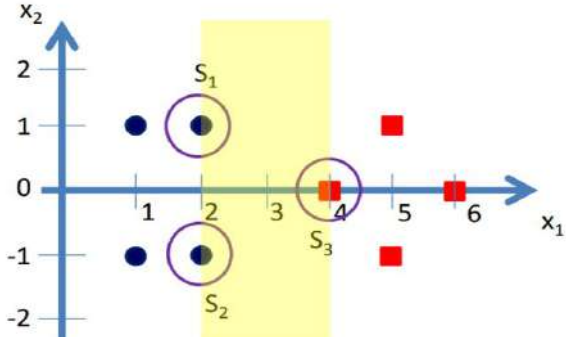
Q.No	Questions	Marks	CO	BL	PI
5b	<p>Consider the following graphical model, which defines a joint probability distribution over five Boolean variables. Apply Expectation Maximization to train this Bayesian network, given training data in which the variables F, S, H and N are fully observed, and where the variable A is sometimes unobserved.</p>  <pre> graph TD     S((S)) --&gt; F((F))     S((S)) --&gt; A((A))     S((S)) --&gt; H((H))     S((S)) --&gt; N((N))   </pre> <p>a. What are the conditional probability distributions associated with each of the five random variables in this network?</p> <p>b. What variables are in the Markov blanket for variable A?</p> <p>c. Given that all variables in the Markov blanket of A are observed, it should be possible to compute the distribution over A based on only these variables. Simplify your expression from part (2) so that it uses only the variables in the Markov blanket of A.</p>	10	CO1	L3	1.4.1
6a	<p>Apply SVM algorithm for the data-points and find dimension of hyper plane to classify the data-points for the figure. (assume bias =1)</p> 	10	CO2	L3	2.1.3
6b	<p>What is linearly in separable problem? Design a two layer network of perceptron to implement XOR and AND gates.</p>	10	CO2	L2	1.4.1
7a	<p>Develop a Q learning task for recommendation system of an online shopping website. What will be the environment of the system? Write the cost function and value function for the system.</p>	10	CO4	L3	2.1.3
7b	<p>Explain how an agent can take action to move from one state to other state with the help of rewards.</p>	10	CO4	L3	1.4.1
8a	<p>Explain reinforcement learning in detail along with the various elements involved in forming the concept. Also define what is meant by partially observed state.</p>	10	CO4	L3	2.1.3
8b	<p>Explain how reinforcement learning problem differs from other function approximation.</p>	10	CO4	L2	1.4.1

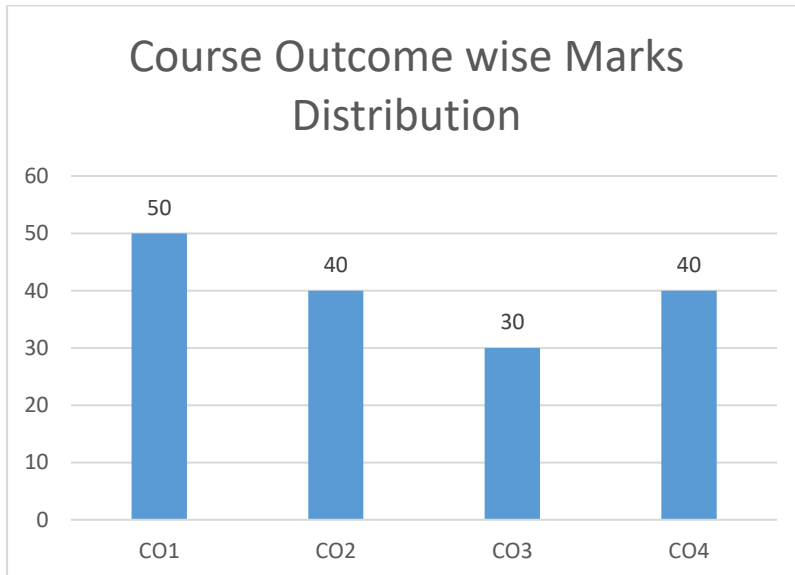
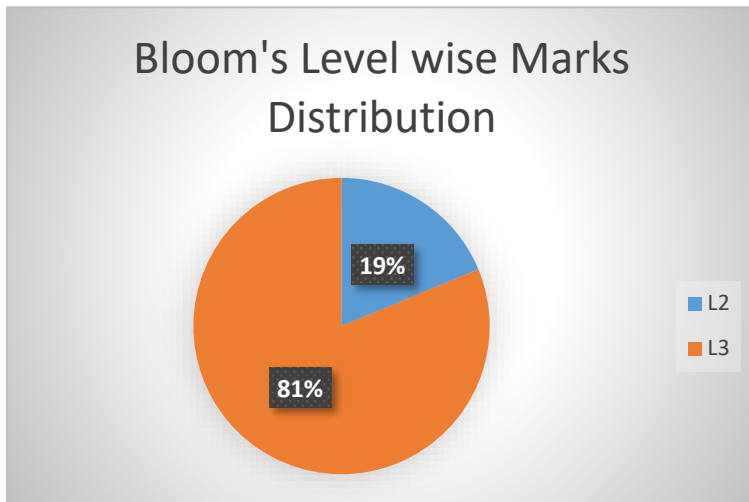

**BL – Bloom’s Taxonomy Levels (1- Remembering, 2- Understanding, 3 – Applying, 4 – Analysing, 5 – Evaluating, 6 - Creating)**

**CO – Course Outcomes**

**PO – Program Outcomes; PI Code – Performance Indicator Code**

## Course Name: Operating System

### Course Outcomes (COs):

At the end of the course the student should be able to:

1. Explain the core structure and functionality of operating system.
2. Evaluate and analyze various algorithms in process management.
3. Describe different deadlock prevention, avoidance and memory management algorithms.
4. Analyze protection and security aspects of mobile and network operating systems.
5. Demonstrate scheduling and memory management algorithms.

Model Question Paper for End Semester Examination							
Course Code:			Course Title: Operating System				
Duration: 3 hrs			Max. Marks: 100				
Note: Answer five questions; any two full questions from each unit-I and unit-II and one full question from unit-III							
Unit-I							
Q.No	Questions		Marks	CO	PI Code	B L	
1 a	Classify and justify the following applications as Batch oriented or Interactive. Generating monthly bank statement, Word processing, Generating personal tax returns.		06	CO1	1.4.1	L2	
b	Discus implementation of mutual exclusion with semaphores. Explain the role of wait( ) and signal( ) functions in this regard.		04	CO1	1.4.1	L2	
c	Consider the following processes with their arrival time and burst time as given below:		10	CO2	1.4.1	L3	
	Process	Arrival Time					Burst Time
	P1	0					12
	P2	2					4
	P3	3					6
	P4	8					5
	Identify appropriate data structure to implement following scheduling algorithms for the above scenario. Which one among them gives optimized scheduling with respect to waiting time? a. FCFS b. Shortest remaining time first ( SJF preemptive) c. Round Robin (time quantum = 4 units)						

2 a	<p>Consider the concurrently running processes A and B as given below. (Shared data: semaphore s1=0, s2=0;)</p> <table style="width: 100%; border: none;"> <tr> <td style="width: 50%; vertical-align: top;"> <p><b>Process A:</b> do { Instruction a; Signal (s1); instruction b; Wait (s2); Instruction e; } while (true);</p> </td> <td style="width: 50%; vertical-align: top;"> <p><b>Process B:</b> do { Wait (s1); Instruction d; Instruction c; Signal (s2); } while (true)</p> </td> </tr> </table> <p>Illustrate the order in which these instructions (A, B, C and D) will get executed?</p>	<p><b>Process A:</b> do { Instruction a; Signal (s1); instruction b; Wait (s2); Instruction e; } while (true);</p>	<p><b>Process B:</b> do { Wait (s1); Instruction d; Instruction c; Signal (s2); } while (true)</p>	10	CO2	1.4.1	L3
<p><b>Process A:</b> do { Instruction a; Signal (s1); instruction b; Wait (s2); Instruction e; } while (true);</p>	<p><b>Process B:</b> do { Wait (s1); Instruction d; Instruction c; Signal (s2); } while (true)</p>						
b	Differentiate between one-to-one and many-to-many model used for multithreading implementation.	10	CO1	1.4.1	L2		
3 a	<p>Assume two operations i) A(counter++) ii) B(counter--)</p> <p>Both are running following code:</p> <pre style="text-align: center;"> reg1= counter; reg1= Reg1+1; Counter = reg1; </pre> <p>Check for occurrence of Race condition. Propose different approaches to solve race condition if it exists.</p>	10	CO1	1.4.1	L3		
3.b	<p>Every Saturday ram will get up at morning 6 o clock. His wife Swapna wants him to help her out with doing the house since guests were expected to arrive that evening. This would take Ram 45 minutes. His daughter Priya wants him to help her out in solving a math problem for 15 min, before she could face a test that afternoon in the tuition classes. Ram's son Arun, wants to be dropped at his friend's place as he is going to movie at 4pm. This would take an hour of travel. Ram's boss now calls him and asks him to call up a client and have a telecon on a particular business deal which would take him 20 minutes. In the evening 4 pm his colleague asks him a help to send one email to client so that in the night client will check and reply. It will take approximately 30 min. As age factor plays imp role Ram will be taking 5 min rest after each work.</p>	10	CO2	1.4.1	L3		



	Implement above situation using FCFS, SJF and RR scheduling algorithms and identify the best one among them (with respect to Turn-around time). Priority will be ranging from professional to personal life.																																																																																														
<b>Unit-II</b>																																																																																															
4a	Suppose that a disk drive has 5000 cylinders, numbered 0 to 4999. The drive is currently serving a request at cylinder 143, and the previous request was at cylinder 125. The queue of pending requests, in FIFO order, is: 86, 1470, 913, 1774, 948, 1509, 1022, 1750, 130 Starting from the current head position, what is the total distance (in cylinders) that the disk arm moves to satisfy all the pending requests for each of the following disk scheduling algorithms? i)FCFS ii) SSTF iii) SCAN iv) LOOK	10	CO3	2.1.3	L3																																																																																										
b	Determine the total amount of internal fragmentation using i) First fit ii) Best fit iii) Worst fit techniques for the memory requests given below:  <table border="1" style="margin-left: auto; margin-right: auto;"> <thead> <tr> <th colspan="2">Memory Requests</th> <th colspan="3">Free regions</th> </tr> <tr> <th>Jobs</th> <th>Request</th> <th>Free Blocks</th> <th>Address</th> <th>Size</th> </tr> </thead> <tbody> <tr> <td>Job 1</td> <td>200 Bytes</td> <td>Free region 1</td> <td>2000-2900</td> <td>900</td> </tr> <tr> <td>Job 2</td> <td>700 Bytes</td> <td>Free region 2</td> <td>5000-5500</td> <td>500</td> </tr> <tr> <td>Job 3</td> <td>50 Bytes</td> <td>Free region 3</td> <td>6000-6800</td> <td>800</td> </tr> <tr> <td>Job 4</td> <td>800 Bytes</td> <td>Free region 4</td> <td>7000-7100</td> <td>100</td> </tr> <tr> <td>Job 5</td> <td>350 Bytes</td> <td>Free region 5</td> <td>8000-8600</td> <td>600</td> </tr> <tr> <td></td> <td></td> <td>Free region 6</td> <td>9000-9300</td> <td>300</td> </tr> </tbody> </table>	Memory Requests		Free regions			Jobs	Request	Free Blocks	Address	Size	Job 1	200 Bytes	Free region 1	2000-2900	900	Job 2	700 Bytes	Free region 2	5000-5500	500	Job 3	50 Bytes	Free region 3	6000-6800	800	Job 4	800 Bytes	Free region 4	7000-7100	100	Job 5	350 Bytes	Free region 5	8000-8600	600			Free region 6	9000-9300	300	10	CO3	1.4.1	L2																																																		
Memory Requests		Free regions																																																																																													
Jobs	Request	Free Blocks	Address	Size																																																																																											
Job 1	200 Bytes	Free region 1	2000-2900	900																																																																																											
Job 2	700 Bytes	Free region 2	5000-5500	500																																																																																											
Job 3	50 Bytes	Free region 3	6000-6800	800																																																																																											
Job 4	800 Bytes	Free region 4	7000-7100	100																																																																																											
Job 5	350 Bytes	Free region 5	8000-8600	600																																																																																											
		Free region 6	9000-9300	300																																																																																											
5a	Consider the following snapshot of a system:  <table border="1" style="margin-left: auto; margin-right: auto;"> <thead> <tr> <th rowspan="2"></th> <th colspan="4">Allocation</th> <th colspan="4">Max</th> <th colspan="4">Available</th> </tr> <tr> <th>A</th> <th>B</th> <th>C</th> <th>D</th> <th>A</th> <th>B</th> <th>C</th> <th>D</th> <th>A</th> <th>B</th> <th>C</th> <th>D</th> </tr> </thead> <tbody> <tr> <td>P0</td> <td>0</td> <td>0</td> <td>1</td> <td>2</td> <td>0</td> <td>0</td> <td>1</td> <td>2</td> <td>1</td> <td>5</td> <td>2</td> <td>0</td> </tr> <tr> <td>P1</td> <td>1</td> <td>0</td> <td>0</td> <td>0</td> <td>1</td> <td>7</td> <td>5</td> <td>0</td> <td></td> <td></td> <td></td> <td></td> </tr> <tr> <td>P2</td> <td>1</td> <td>3</td> <td>5</td> <td>4</td> <td>2</td> <td>3</td> <td>5</td> <td>6</td> <td></td> <td></td> <td></td> <td></td> </tr> <tr> <td>P3</td> <td>0</td> <td>6</td> <td>3</td> <td>2</td> <td>0</td> <td>6</td> <td>5</td> <td>2</td> <td></td> <td></td> <td></td> <td></td> </tr> <tr> <td>P4</td> <td>0</td> <td>0</td> <td>1</td> <td>4</td> <td>0</td> <td>6</td> <td>5</td> <td>6</td> <td></td> <td></td> <td></td> <td></td> </tr> </tbody> </table> <p>Answer the following questions using the Banker’s algorithm:</p> <p>a. Is the system in a safe state?</p> <p>b. If a request from process P4 arrives for (0, 3, 2, 0), can the request be granted immediately?</p>		Allocation				Max				Available				A	B	C	D	A	B	C	D	A	B	C	D	P0	0	0	1	2	0	0	1	2	1	5	2	0	P1	1	0	0	0	1	7	5	0					P2	1	3	5	4	2	3	5	6					P3	0	6	3	2	0	6	5	2					P4	0	0	1	4	0	6	5	6					10	CO3	2.1.3	L3
	Allocation				Max				Available																																																																																						
	A	B	C	D	A	B	C	D	A	B	C	D																																																																																			
P0	0	0	1	2	0	0	1	2	1	5	2	0																																																																																			
P1	1	0	0	0	1	7	5	0																																																																																							
P2	1	3	5	4	2	3	5	6																																																																																							
P3	0	6	3	2	0	6	5	2																																																																																							
P4	0	0	1	4	0	6	5	6																																																																																							
b	Determine the total number of page faults and page fault rate for the reference string given below using following page replacement algorithms. i) FIFO ii) Optimal iii) LRU (Assume Number of frames = 4) Reference string: 3, 2, 5, 0, 1, 3, 5, 0, 7, 8, 2, 1, 2, 3, 4, 5, 8, 4, 7, 8	10	CO3	1.4.1	L3																																																																																										

6a	Suppose at time T <sub>0</sub> , we have the following resource allocation state: <table border="1" style="margin-left: auto; margin-right: auto;"> <thead> <tr> <th></th> <th colspan="3">Allocation</th> <th></th> <th colspan="3">Request</th> <th></th> <th colspan="3">Available</th> </tr> <tr> <th></th> <th>A</th> <th>B</th> <th>C</th> <th></th> <th>A</th> <th>B</th> <th>C</th> <th></th> <th>A</th> <th>B</th> <th>C</th> </tr> </thead> <tbody> <tr> <td>P<sub>0</sub></td> <td>0</td> <td>1</td> <td>0</td> <td></td> <td>0</td> <td>0</td> <td>0</td> <td></td> <td>0</td> <td>0</td> <td>0</td> </tr> <tr> <td>P<sub>1</sub></td> <td>2</td> <td>0</td> <td>0</td> <td></td> <td>2</td> <td>0</td> <td>2</td> <td></td> <td></td> <td></td> <td></td> </tr> <tr> <td>P<sub>2</sub></td> <td>3</td> <td>0</td> <td>3</td> <td></td> <td>0</td> <td>0</td> <td>0</td> <td></td> <td></td> <td></td> <td></td> </tr> <tr> <td>P<sub>3</sub></td> <td>2</td> <td>1</td> <td>1</td> <td></td> <td>1</td> <td>0</td> <td>0</td> <td></td> <td></td> <td></td> <td></td> </tr> <tr> <td>P<sub>4</sub></td> <td>0</td> <td>0</td> <td>2</td> <td></td> <td>0</td> <td>0</td> <td>2</td> <td></td> <td></td> <td></td> <td></td> </tr> </tbody> </table> <p>Using deadlock detection algorithm test whether the system is in a deadlock state.</p>		Allocation				Request				Available				A	B	C		A	B	C		A	B	C	P <sub>0</sub>	0	1	0		0	0	0		0	0	0	P <sub>1</sub>	2	0	0		2	0	2					P <sub>2</sub>	3	0	3		0	0	0					P <sub>3</sub>	2	1	1		1	0	0					P <sub>4</sub>	0	0	2		0	0	2					10	CO3	1.4.1	L3
	Allocation				Request				Available																																																																																
	A	B	C		A	B	C		A	B	C																																																																														
P <sub>0</sub>	0	1	0		0	0	0		0	0	0																																																																														
P <sub>1</sub>	2	0	0		2	0	2																																																																																		
P <sub>2</sub>	3	0	3		0	0	0																																																																																		
P <sub>3</sub>	2	1	1		1	0	0																																																																																		
P <sub>4</sub>	0	0	2		0	0	2																																																																																		
b	With neat diagram describe the Paging hardware with translation look-aside buffer (TLB). Also calculate the effective memory access time for the following specification. Hit ratio = 60%. Memory access time = 200 nano seconds TLB search time = 50 nano seconds	10	CO3	2.1.3	L3																																																																																				
<b>Unit III</b>																																																																																									
7a	Discuss the strengths and weaknesses of implementing an access matrix using access lists that are associated with objects.	10	CO4	1.4.1	L2																																																																																				
b	Explain why a capability-based system such as Hydra provides greater flexibility than the ring-protection scheme in enforcing protection policies.	10	CO4	1.4.1	L3																																																																																				
8a	Explain overall architecture of Android Operating system. What are the benefits of using Android for Mobile application development	10	CO4	1.4.1	L2																																																																																				
b	Discuss design issues of network operating systems. Comment on use of dedicated routers/gateways against general purpose computers for networking.	10	CO4	1.4.1	L3																																																																																				

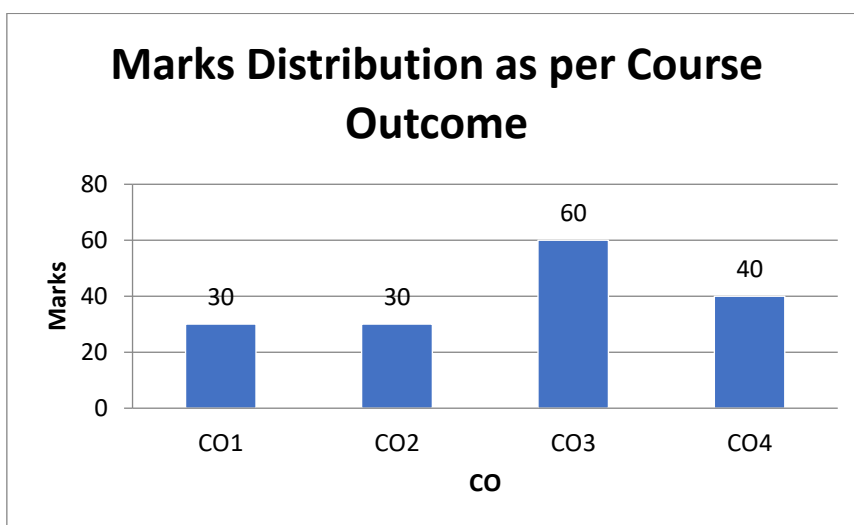
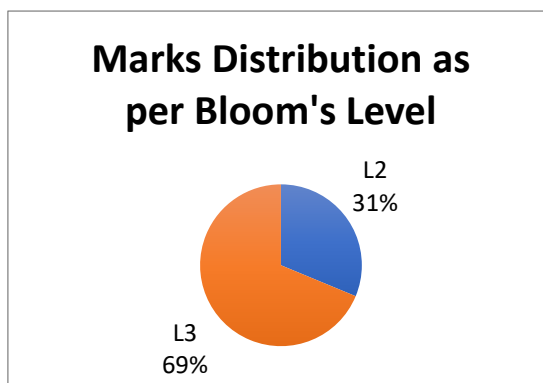

**\*CO5 is addresses through Course Activity.**

BL – Bloom’s Taxonomy Levels (1- Remembering, 2- Understanding, 3 – Applying, 4 – Analysing, 5 – Evaluating, 6 - Creating)

CO – Course Outcomes

PO – Program Outcomes; PI Code – Performance Indicator Code

### Competency addressed in the Course and corresponding Performance Indicators

Competency	Performance Indicators
1.4: Demonstrate competence in computer science engineering knowledge.	1.4.1. Apply knowledge of suitable data structures and / or programming paradigm to solve problems.
2.1 :Demonstrate an ability to identify and characterize an engineering problem	2.1.3. Identify the mathematical, engineering and other relevant knowledge that applies to a given problem.

**Model Question Paper**  
**Total Duration (H:M): 3:00**  
**Course : Data Mining and Analysis**  
**Maximum Marks :100**

Q.No.	Questions	Marks	CO	BL	PI												
1a)	<p>Answer the following questions with justification.</p> <p>(i) Is noise ever interesting or desirable?</p> <p>(ii) Can noise objects be outliers?</p> <p>(iii) Are noise objects always outliers?</p> <p>(iv) Are outliers always noise objects?</p> <p>(v) Can noise make a typical value into an unusual one, or vice versa?</p>	10	CO1	L3	1.1.3												
1b)	<p>Consider the following database of travel sequences for one working week of a traveler:</p> <table border="1" style="margin-left: auto; margin-right: auto;"> <thead> <tr> <th>Day</th> <th>Sequence</th> </tr> </thead> <tbody> <tr> <td>Mon</td> <td>A, U, H, U, A</td> </tr> <tr> <td>Tue</td> <td>A, U, H, U, B</td> </tr> <tr> <td>Wed</td> <td>B, A</td> </tr> <tr> <td>Thu</td> <td>A, U, H, U, A</td> </tr> <tr> <td>Fri</td> <td>A, U, B</td> </tr> </tbody> </table> <p>(i) Use the Apriori algorithm to compute all frequent itemsets, and their support, with minimum support 3. Clearly indicate the steps of the algorithm, and the pruning that is performed.</p> <p>(ii) Which of the frequent sequences are maximal?</p> <p>(iii) Which of the frequent sequences are closed?</p>	Day	Sequence	Mon	A, U, H, U, A	Tue	A, U, H, U, B	Wed	B, A	Thu	A, U, H, U, A	Fri	A, U, B	10	CO2	L3	2.1.4
Day	Sequence																
Mon	A, U, H, U, A																
Tue	A, U, H, U, B																
Wed	B, A																
Thu	A, U, H, U, A																
Fri	A, U, B																
2a)	<p>(i) For the Traveler dataset given in Figure 3.a, answer the following questions:</p> <p>[A] Which kind of plots are suitable for each of the 'gender', 'signup_method', 'first_device_type', 'first_browser' and 'timestamp_first_active' attributes.</p> <p>[B] Which kind of plots are suitable for numerical data, give example.</p> <p>[C] Classify each of the following attributes {'id', 'date_account_created', 'timestamp_first_active', 'gender', 'age', 'country_destination'} as qualitative (nominal or ordinal or binary) or quantitative (discrete or continuous). Some cases may have more than one interpretation, briefly indicate your reasoning if you think there may be some ambiguity.</p> <p>(ii) List and briefly describe two other techniques for numerosity reduction.</p>	6 + 4	CO1	L3	1.4.1												

<p>2b)</p>	<p>(i) Draw a contingency table for each of the rules using the transactions shown in Table 2.b.                  Rules: [A] {b} → {c}; [B] {a} → {d}; [C] {b} → {d};                  [D] {e} → {c}; [E] {c} → {a};</p> <table border="1" data-bbox="386 338 1023 786"> <thead> <tr> <th colspan="2">Table 2.b: Market basket transactions</th> </tr> <tr> <th>Transaction ID</th> <th>Item Brought</th> </tr> </thead> <tbody> <tr><td>0001</td><td>{a, b, d, e}</td></tr> <tr><td>0002</td><td>{b, c, d}</td></tr> <tr><td>0003</td><td>{a, b, d, e}</td></tr> <tr><td>0004</td><td>{a, c, d, e}</td></tr> <tr><td>0005</td><td>{b, c, d, e}</td></tr> <tr><td>0006</td><td>{b, d, e}</td></tr> <tr><td>0007</td><td>{c, d}</td></tr> <tr><td>0008</td><td>{a, b, c}</td></tr> <tr><td>0009</td><td>{b, d, e}</td></tr> <tr><td>0010</td><td>{b, d}</td></tr> </tbody> </table> <p>(ii) Use the contingency tables obtained in part (i) to compute and rank the rules in decreasing order according to the following measures:                  [A] Support; [B] Confidence; [C] Interest <math>(X \rightarrow Y) = P(X, Y) / (P(X)*P(Y))</math></p>	Table 2.b: Market basket transactions		Transaction ID	Item Brought	0001	{a, b, d, e}	0002	{b, c, d}	0003	{a, b, d, e}	0004	{a, c, d, e}	0005	{b, c, d, e}	0006	{b, d, e}	0007	{c, d}	0008	{a, b, c}	0009	{b, d, e}	0010	{b, d}	<p>5 + 5</p>	<p>CO2</p>	<p>L3</p>	<p>2.1.4</p>																																																																														
Table 2.b: Market basket transactions																																																																																																											
Transaction ID	Item Brought																																																																																																										
0001	{a, b, d, e}																																																																																																										
0002	{b, c, d}																																																																																																										
0003	{a, b, d, e}																																																																																																										
0004	{a, c, d, e}																																																																																																										
0005	{b, c, d, e}																																																																																																										
0006	{b, d, e}																																																																																																										
0007	{c, d}																																																																																																										
0008	{a, b, c}																																																																																																										
0009	{b, d, e}																																																																																																										
0010	{b, d}																																																																																																										
<p>3a)</p>	<table border="1" data-bbox="210 929 1182 1691"> <thead> <tr> <th></th> <th>0</th> <th>1</th> <th>2</th> <th>3</th> <th>4</th> </tr> </thead> <tbody> <tr> <td>id</td> <td>gxn3p5htnn</td> <td>820tgsjq7</td> <td>4ft3gnwmtx</td> <td>bjjt8pjhuk</td> <td>87mebub9p4</td> </tr> <tr> <td>date_account_created</td> <td>2010-06-28</td> <td>2011-05-25</td> <td>2010-09-28</td> <td>2011-12-05</td> <td>2010-09-14</td> </tr> <tr> <td>timestamp_first_active</td> <td>20090319043255</td> <td>20090523174809</td> <td>20090609231247</td> <td>20091031060129</td> <td>20091208061105</td> </tr> <tr> <td>date_first_booking</td> <td>NaN</td> <td>NaN</td> <td>2010-08-02</td> <td>2012-09-08</td> <td>2010-02-18</td> </tr> <tr> <td>gender</td> <td>-unknown-</td> <td>MALE</td> <td>FEMALE</td> <td>FEMALE</td> <td>-unknown-</td> </tr> <tr> <td>age</td> <td>NaN</td> <td>38</td> <td>56</td> <td>42</td> <td>41</td> </tr> <tr> <td>signup_method</td> <td>facebook</td> <td>facebook</td> <td>basic</td> <td>facebook</td> <td>basic</td> </tr> <tr> <td>signup_flow</td> <td>0</td> <td>0</td> <td>3</td> <td>0</td> <td>0</td> </tr> <tr> <td>language</td> <td>en</td> <td>en</td> <td>en</td> <td>en</td> <td>en</td> </tr> <tr> <td>affiliate_channel</td> <td>direct</td> <td>seo</td> <td>direct</td> <td>direct</td> <td>direct</td> </tr> <tr> <td>affiliate_provider</td> <td>direct</td> <td>google</td> <td>direct</td> <td>direct</td> <td>direct</td> </tr> <tr> <td>first_affiliate_tracked</td> <td>untracked</td> <td>untracked</td> <td>untracked</td> <td>untracked</td> <td>untracked</td> </tr> <tr> <td>signup_app</td> <td>Web</td> <td>Web</td> <td>Web</td> <td>Web</td> <td>Web</td> </tr> <tr> <td>first_device_type</td> <td>Mac Desktop</td> <td>Mac Desktop</td> <td>Windows Desktop</td> <td>Mac Desktop</td> <td>Mac Desktop</td> </tr> <tr> <td>first_browser</td> <td>Chrome</td> <td>Chrome</td> <td>IE</td> <td>Firefox</td> <td>Chrome</td> </tr> <tr> <td>country_destination</td> <td>NDF</td> <td>NDF</td> <td>US</td> <td>other</td> <td>US</td> </tr> </tbody> </table> <p>Fig. 3. a.: Sample Traveler dataset</p> <p>(i) For the Traveler dataset given in Figure 3. a, write the appropriate one or two line python code for the following questions:                  [A] <b>Code:</b> To find what is the percentage of data missing in each of the attributes?                  [B] <b>Inference:</b> What kind of analysis do you infer from distribution plot shown below.</p>		0	1	2	3	4	id	gxn3p5htnn	820tgsjq7	4ft3gnwmtx	bjjt8pjhuk	87mebub9p4	date_account_created	2010-06-28	2011-05-25	2010-09-28	2011-12-05	2010-09-14	timestamp_first_active	20090319043255	20090523174809	20090609231247	20091031060129	20091208061105	date_first_booking	NaN	NaN	2010-08-02	2012-09-08	2010-02-18	gender	-unknown-	MALE	FEMALE	FEMALE	-unknown-	age	NaN	38	56	42	41	signup_method	facebook	facebook	basic	facebook	basic	signup_flow	0	0	3	0	0	language	en	en	en	en	en	affiliate_channel	direct	seo	direct	direct	direct	affiliate_provider	direct	google	direct	direct	direct	first_affiliate_tracked	untracked	untracked	untracked	untracked	untracked	signup_app	Web	Web	Web	Web	Web	first_device_type	Mac Desktop	Mac Desktop	Windows Desktop	Mac Desktop	Mac Desktop	first_browser	Chrome	Chrome	IE	Firefox	Chrome	country_destination	NDF	NDF	US	other	US	<p>5 + 5</p>	<p>CO1</p>	<p>L3</p>	<p>1.4.1</p>
	0	1	2	3	4																																																																																																						
id	gxn3p5htnn	820tgsjq7	4ft3gnwmtx	bjjt8pjhuk	87mebub9p4																																																																																																						
date_account_created	2010-06-28	2011-05-25	2010-09-28	2011-12-05	2010-09-14																																																																																																						
timestamp_first_active	20090319043255	20090523174809	20090609231247	20091031060129	20091208061105																																																																																																						
date_first_booking	NaN	NaN	2010-08-02	2012-09-08	2010-02-18																																																																																																						
gender	-unknown-	MALE	FEMALE	FEMALE	-unknown-																																																																																																						
age	NaN	38	56	42	41																																																																																																						
signup_method	facebook	facebook	basic	facebook	basic																																																																																																						
signup_flow	0	0	3	0	0																																																																																																						
language	en	en	en	en	en																																																																																																						
affiliate_channel	direct	seo	direct	direct	direct																																																																																																						
affiliate_provider	direct	google	direct	direct	direct																																																																																																						
first_affiliate_tracked	untracked	untracked	untracked	untracked	untracked																																																																																																						
signup_app	Web	Web	Web	Web	Web																																																																																																						
first_device_type	Mac Desktop	Mac Desktop	Windows Desktop	Mac Desktop	Mac Desktop																																																																																																						
first_browser	Chrome	Chrome	IE	Firefox	Chrome																																																																																																						
country_destination	NDF	NDF	US	other	US																																																																																																						

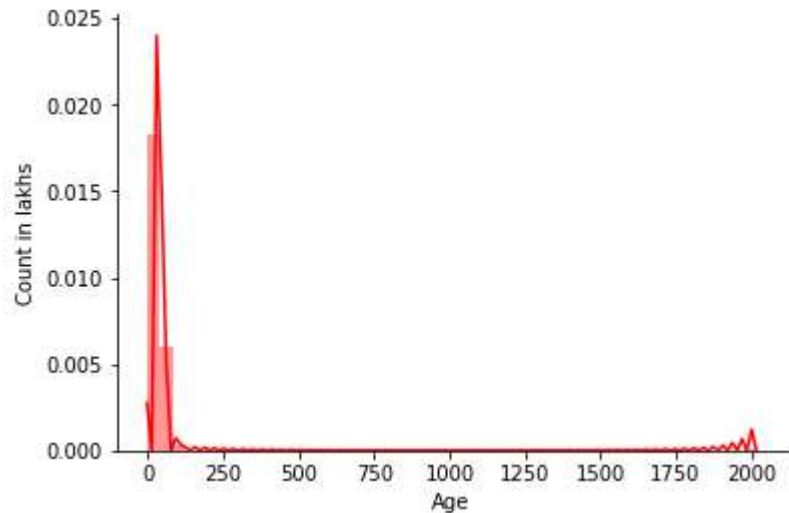

[C] **Code:** To find are there any outliers in the age attribute and specify how do you remove noise and outliers from the age attribute.

(ii) Write your **Inference** from these codes (users is a DataFrame depicted in Fig. 3.a).

[D] `users.gender.replace('-unknown-', np.nan, inplace=True)`

`users.gender.value_counts(dropna = False).plot(kind='bar', color='red', rot=45)`

[E] `users['date_first_active'] = pd.to_datetime((users.timestamp_first_active), format='%Y%m%d')`

[F] `gender0 = sum(users['gender'] == 'FEMALE')`  
`gender1 = sum(users['gender'] == 'MALE')`  
`gender0_0 = users.loc[users['gender'] == 'FEMALE', 'country_destination'].value_counts() / gender0 * 100`  
`gender1_1 = users.loc[users['gender'] == 'MALE', 'country_destination'].value_counts() / gender1 * 100`

3b)	<p>True or False/ Yes or No/ Short answers/Inference from analysis.</p> <p>(i) [True/False] In comparison with the performance of a base classifier on a particular data set, bagging will generally not increase the error whereas as boosting may lead to an increase in the error.</p> <p>(ii) [True/False] The use of weak classifiers prevents overfitting when we perform bagging.</p> <p>(iii) [True/False] If one feature (compared to all others) is a very strong predictor of the class label of the output variable, then all of the trees in a random forest will have this feature as the root node.</p> <p>(iv) [True/False] Is AdaBoost sensitive to outliers?</p> <p>(v) [Yes/No] On a particular data set, we use the ensemble method approach to building a predictor and achieve state of the art performance. Is it possible for some of the individual models in this ensemble to have poor performance as measured on the training data?</p> <p>(vi) [Yes/No] Consider an alternative way of learning a Random Forest where instead of randomly sampling the attributes at each node, we sample a subset of attributes for each tree and build the tree on these features. Would you prefer this method over the original or not, and why?</p> <p>(vii) [Yes/No] Can the boosting technique be applied on regression problems? Can bagging be applied on regression problems?</p> <p>(viii) While working on a recognition problem, we implemented four different classifiers. You are now trying to compare their performance. Their misclassification rates are as follows:</p> <table border="1" data-bbox="210 1323 1102 1525"> <thead> <tr> <th></th> <th>Classifier P</th> <th>Classifier Q</th> <th>Classifier R</th> <th>Classifier S</th> </tr> </thead> <tbody> <tr> <td>Error rate on training data</td> <td>25%</td> <td>5%</td> <td>10%</td> <td>20%</td> </tr> <tr> <td>Error rate on testing data</td> <td>30%</td> <td>20%</td> <td>15%</td> <td>25%</td> </tr> </tbody> </table> <p>Write Classifier P, Q, R, or S.</p> <p>[A] Which classifier has the best generalization performance, i.e., most likely would perform the best when applied to unseen data?</p> <p>[B] Which classifier is underfitting the most?</p> <p>[C] Which classifier is overfitting the most?</p>		Classifier P	Classifier Q	Classifier R	Classifier S	Error rate on training data	25%	5%	10%	20%	Error rate on testing data	30%	20%	15%	25%	10	CO3	L3	2.1.4
	Classifier P	Classifier Q	Classifier R	Classifier S																
Error rate on training data	25%	5%	10%	20%																
Error rate on testing data	30%	20%	15%	25%																

4a)	<p>Given the contingency table, compute the following pairwise measures for clustering evaluation:</p> <p>(i) Jaccard coefficient</p> <p>(ii) Rand statistic</p> <p>(iii) Fowlkes–Mallows measure</p>	10	CO3	L2	1.1.3																																				
<p style="text-align: center;"><b>Contingency table</b></p> <table border="1" style="margin-left: auto; margin-right: auto;"> <thead> <tr> <th>C\T</th> <th>T1</th> <th>T2</th> <th>T3</th> </tr> </thead> <tbody> <tr> <th>C1</th> <td>0</td> <td>47</td> <td>14</td> </tr> <tr> <th>C2</th> <td>50</td> <td>0</td> <td>0</td> </tr> <tr> <th>C3</th> <td>0</td> <td>3</td> <td>36</td> </tr> </tbody> </table>		C\T	T1	T2	T3	C1	0	47	14	C2	50	0	0	C3	0	3	36																								
C\T	T1	T2	T3																																						
C1	0	47	14																																						
C2	50	0	0																																						
C3	0	3	36																																						
4b)	<p>Solve the following <b>HAC</b> by considering the proximity matrix given, and consider inter-cluster similarity between clusters using:</p> <p>(i) Nearest neighbor linkage</p> <p>(ii) Farthest neighbor linkage</p> <p>And draw the corresponding dendograms.</p>	10	CO2	L3	2.1.4																																				
<p style="text-align: center;"><b>Proximity matrix</b></p> <table border="1" style="margin-left: auto; margin-right: auto;"> <thead> <tr> <th></th> <th>P1</th> <th>P2</th> <th>P3</th> <th>P4</th> <th>P5</th> </tr> </thead> <tbody> <tr> <th>P1</th> <td>1.00</td> <td>0.10</td> <td>0.41</td> <td>0.55</td> <td>0.35</td> </tr> <tr> <th>P2</th> <td>0.10</td> <td>1.00</td> <td>0.64</td> <td>0.47</td> <td>0.98</td> </tr> <tr> <th>P3</th> <td>0.41</td> <td>0.64</td> <td>1.00</td> <td>0.44</td> <td>0.85</td> </tr> <tr> <th>P4</th> <td>0.55</td> <td>0.47</td> <td>0.44</td> <td>1.00</td> <td>0.76</td> </tr> <tr> <th>P5</th> <td>0.35</td> <td>0.98</td> <td>0.85</td> <td>0.76</td> <td>1.00</td> </tr> </tbody> </table>			P1	P2	P3	P4	P5	P1	1.00	0.10	0.41	0.55	0.35	P2	0.10	1.00	0.64	0.47	0.98	P3	0.41	0.64	1.00	0.44	0.85	P4	0.55	0.47	0.44	1.00	0.76	P5	0.35	0.98	0.85	0.76	1.00				
	P1	P2	P3	P4	P5																																				
P1	1.00	0.10	0.41	0.55	0.35																																				
P2	0.10	1.00	0.64	0.47	0.98																																				
P3	0.41	0.64	1.00	0.44	0.85																																				
P4	0.55	0.47	0.44	1.00	0.76																																				
P5	0.35	0.98	0.85	0.76	1.00																																				
5a)	<p>Consider the following data set:</p> <table border="1" style="margin-left: auto; margin-right: auto;"> <thead> <tr> <th>V</th> <th>W</th> <th>X</th> <th>Y</th> </tr> </thead> <tbody> <tr> <td>0</td> <td>0</td> <td>0</td> <td>0</td> </tr> <tr> <td>0</td> <td>1</td> <td>0</td> <td>1</td> </tr> <tr> <td>1</td> <td>0</td> <td>0</td> <td>1</td> </tr> <tr> <td>1</td> <td>1</td> <td>0</td> <td>0</td> </tr> <tr> <td>1</td> <td>1</td> <td>1</td> <td>0</td> </tr> </tbody> </table> <p>Your task is to build a <b>decision tree</b> for classifying variable Y. (You can think of the data set as replicated many times, i.e. overfitting is not an issue here).</p> <p>(i) Compute the information gains <math>IG(Y   V)</math>, <math>IG(Y   W)</math> and <math>IG(Y   X)</math>. Which attribute would Decision Tree classifier select first?</p> <p>(ii) Write down the entire decision tree constructed by Decision Tree classifier, without pruning.</p> <p>(iii) One idea for pruning would be to start at the root, and prune splits for which the information gain (or some other criterion) is less than some small <math>\epsilon</math>.</p>	V	W	X	Y	0	0	0	0	0	1	0	1	1	0	0	1	1	1	0	0	1	1	1	0	10	CO2	L3	2.1.4												
V	W	X	Y																																						
0	0	0	0																																						
0	1	0	1																																						
1	0	0	1																																						
1	1	0	0																																						
1	1	1	0																																						



	<p>This is called top-down pruning. What is the decision tree returned for <math>\epsilon = 0.0001</math>? What is the training set error for this tree?</p> <p>(iv) Another option would be to start at the leaves, and prune subtrees for which the information gain (or some other criterion) of a split is less than some small <math>\epsilon</math>. In this method, no ancestors of children with high information gain will get pruned. This is called bottom-up pruning. What is the tree returned for <math>\epsilon = 0.0001</math>? What is the training set error for this tree?</p>				
5b)	<p>i) You are given a training set of five real-valued points and their 2-class classifications (+or -): (1.5, +), (3.2, +), (5.4, -), (6.2, -), (8.5, -).</p> <p>[A] What is the predicted class for a test example at point 4.0 using 3-NN?</p> <p>[B] What is the decision boundary associated with this Training set using 3-NN? (Hint: The boundary is defined by a single real value.)</p> <p>[C] True or False (Justify): For <i>any</i> 2-class, linearly-separable Training set (e.g., the one given above), a 3-NN classifier will always have 100% accuracy on the Training set.</p> <p>(ii) Say we have a Training set consisting of 30 positive examples and 10 negative examples where each example is a point in a two-dimensional, real-valued feature space.</p> <p>[A] What will the classification accuracy be on the Training set with 1-NN?</p> <p>[B] What will the classification accuracy be on the Training set with 40-NN?</p>	10	CO3	L3	2.1.4

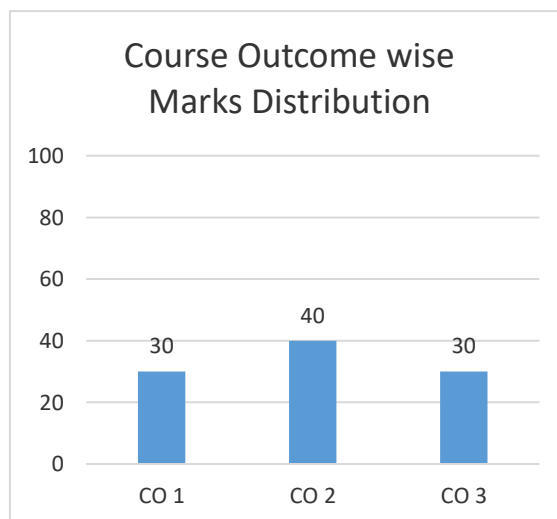
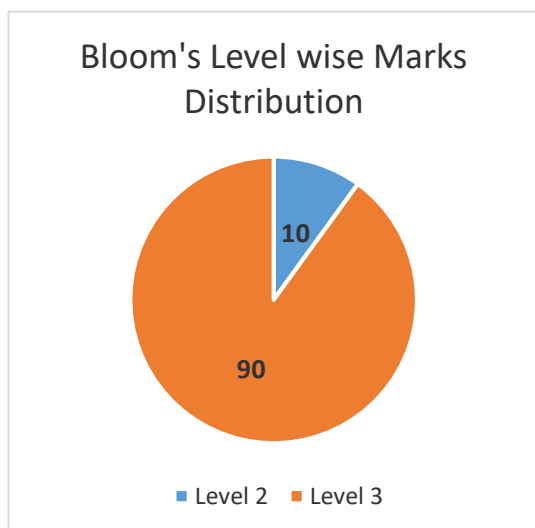

**BL – Bloom’s Taxonomy Levels (1- Remembering, 2- Understanding, 3 – Applying, 4 – Analysing, 5 – Evaluating, 6 - Creating)**

**CO – Course Outcomes**

**PO – Program Outcomes; PI Code – Performance Indicator Code**

# Electrical & Electronics Engineering

## Model Question Paper

### For Undergraduate Program

The model question papers are suggestive blueprints. The primary aim of these question papers is to bring clarity about the process of connecting questions to performance indicators and hence to course outcomes. Further, these question papers demonstrate how bloom's taxonomy can be used to understand the quality of question papers and their effectiveness in assessing higher order abilities. The structure of question papers, number of questions, choices given, time given for examination etc., can vary based on the practices of the University or college.

# Table of Contents

<b>Name of Course</b>	<b>Page No.</b>
1. Circuit Analysis	EEE1- EEE6
2. Linear Control Systems	EEE7- EEE10
3. Analog Electronics Circuits	EEE11- EEE16
4. Digital Signal Processing	EEE17- EEE20
5. Power Electronics	EEE21- EEE23

## Course Name: Circuit Analysis

### Course Outcomes (COs):

At the end of the course the student should be able to:

1. Analyze linear circuits using Nodal & Mesh Analysis
2. Apply Network theorems to both AC & DC circuits
3. Employ two port network models to represent active and passive networks
4. Analyze and determine the transient response, time domain and frequency domain behavior of First order circuits
5. Analyze and predict the time domain and frequency domain behavior of Higher order circuits
6. Analyze and draw phasor diagrams for single phase circuits
7. Analyze and draw phasor diagrams for three phase circuits
8. Utilize simulation tool (such as PSpice, Microcap) to accurately analyze circuits

**Model Question Paper**

**Course: Circuit Analysis**

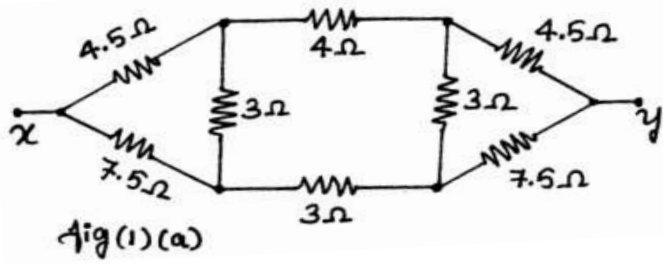
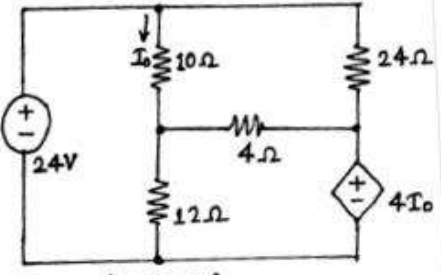
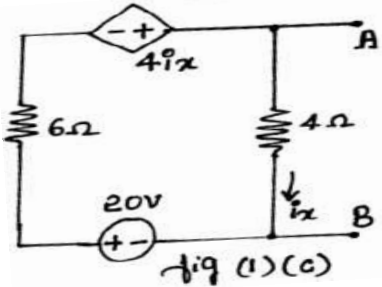
Q.No.	Questions	Marks	CO	BL	PI Code
1a	<p>Use Y-<math>\Delta</math> and <math>\Delta</math>-Y transformation to find <math>R_{th}</math> between points xy. (fig.1.(a)).</p>  <p>Fig (1) (a)</p>	6	CO1	L3	1.4.1
1b	<p>Apply Norton's theorem to find '<math>I_0</math>' in the circuit given (fig.1.(b)).</p>  <p>Fig (1) (b)</p>	6	CO2	L3	1.4.1
1c	<p>For the circuit (fig.1.(c)) given find, i. Thevenin's equivalent circuit at terminals A &amp; B. ii. How much power would be delivered to a resistor connected to AB if <math>R_{AB}=5\Omega</math></p>  <p>Fig (1) (c)</p>	8	CO2	L3	1.4.1
2a	<p>State and prove Maximum power transfer theorem for an AC circuit having impedance source &amp; pure resistive load.</p>	6	CO2	L2	1.4.1

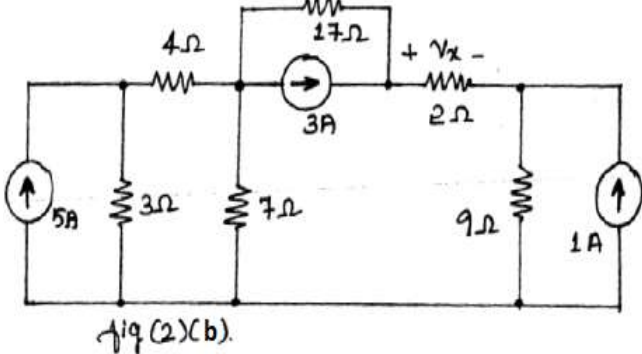
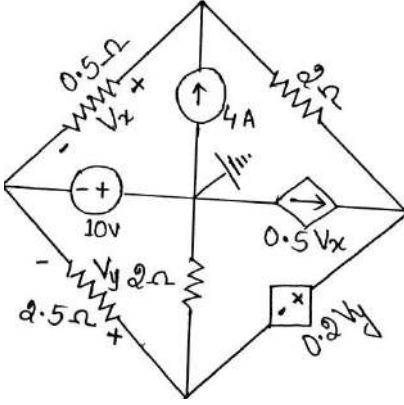
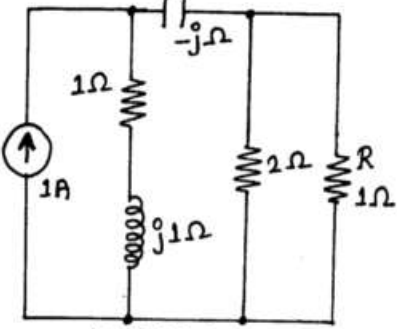
Q.No.	Questions	Marks	CO	BL	PI Code
2b	<p>Determine the voltage 'V<sub>x</sub>' across the 2Ω resistor using source transformation method (fig.2.(b)).</p>  <p style="text-align: center;">fig.2.(b)</p>	6	CO1	L3	1.4.1
2c	<p>Solve for V<sub>x</sub> &amp; V<sub>y</sub> using the supernode concept for the circuit shown in Fig. 2(c).</p> 	8	CO1	L3	1.4.1
3a	<p>Demonstrate Reciprocity theorem for the voltage across R, for the network shown in fig.3.(a).</p>  <p style="text-align: center;">fig.3.(a)</p>	6	CO2	L3	1.4.1
3b	<p>A very long string of 400 multicolored outdoor lights is installed on a house. After applying power, the home owner notices two bulbs are burnt out. i) Are the lights connected in series or parallel? ii) After replacing the burnt bulbs the owner notices that the lights closest to the supply are approximately 10% brighter than the lights at the far end of the string, provide</p>	6	CO1	L3	2.1.3

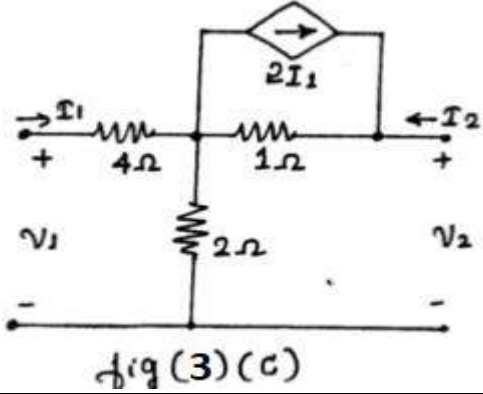
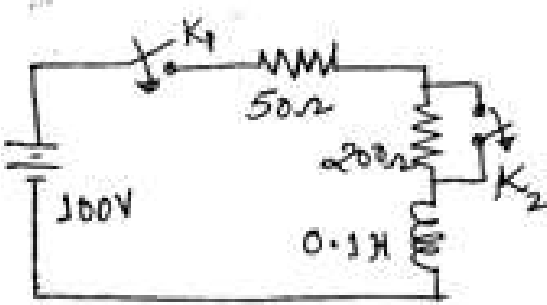
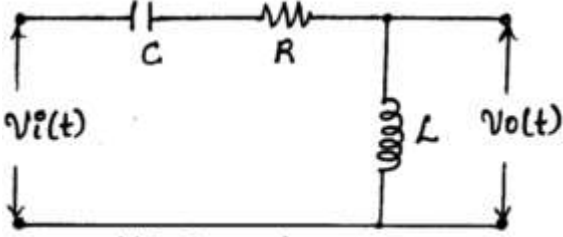
Q.No.	Questions	Marks	CO	BL	PI Code
	<p>a suitable explanation keeping in mind that nothing in the string is zero ohms. iii) Assuming 115V ac supply, individual bulb rating of 1Watt, determine the power supplied by the supply.</p>				
3c	<p>Find hybrid &amp; ABCD parameters of the network shown in fig.3.(c)</p>  <p style="text-align: center;">fig (3) (c)</p>	8	CO3	L3	1.4.1
4a	<p>In the circuit of Fig 4(a), the switch K1 &amp; K2 are closed at <math>t = 0</math> secs and switch K2 is opened at <math>t = 5</math> ms. Find the expression for the resulting value of the current.</p> 	6	CO4	L3	1.4.1
4b	<p>A unit pulse of width 'a' is applied to a RL series circuit. Determine the expression for the current. Given <math>R = 1\Omega</math> and <math>L = 1H</math>.</p>	6	CO4	L2	1.4.1
4c	<p>For the circuit shown in fig.4.(c), derive the transfer function, find order of system, pole-zero location and frequency response.</p>  <p style="text-align: center;">fig (4) (c)</p>	8	CO5	L3	1.4.1
5a	<p>Refer the network shown in fig.5.(a), the switch 'k' is opens at <math>t=0</math>, at <math>t=0+</math> solve for the values of 'v' &amp; <math>dv/dt</math>, if <math>I=2A</math>, <math>R=200\Omega</math> and <math>L=1H</math>.</p>	6	CO4	L3	1.4.1

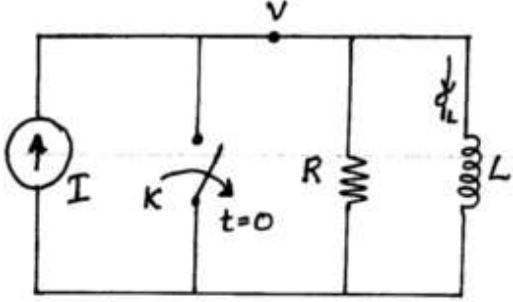
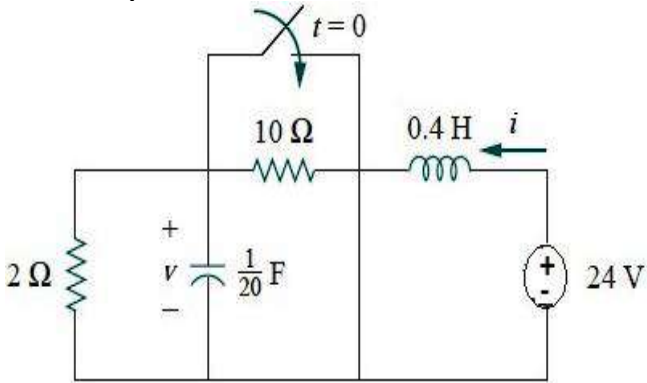
Q.No.	Questions	Marks	CO	BL	PI Code
	 <p style="text-align: center;">Fig (5)(a)</p>				
5b	<p>Explain Series resonance with characteristics and derive the relation between resonant and half power frequencies.</p>	6	CO5	L2	1.4.1
5c	<p>An a.c series circuit consisting of a coil connected in series with a capacitor and resistor. The circuit draws a maximum current of 10A when connected to 200V, 50Hz supply. If the voltage across the capacitor is 500V at resonance, find the parameters R, L &amp; C of the circuit and Quality factor.</p>	8	CO4	L2	1.4.1
6a	<p>Design a circuit to allow a room light to remain 'ON' for 5Sec after the switch has been turned 'OFF'. Assume 40W bulb and 115 Ohm AC supply.</p>	6	CO4	L3	2.1.3
6b	<p>Derive the expression for dynamic resistance and resonant frequency in parallel resonant tank circuit.</p>	6	CO5	L3	1.4.1
6c	<p>The switch in Fig.6(c) was open for a long time but closed at <math>t = 0</math>. Determine expressions for <math>i</math> and <math>v</math>.</p> 	8	CO5	L3	1.4.1
7a	<p>A parallel RLC circuit comprising of a capacitor <math>B_C=0.3S</math>, inductor <math>B_L=0.1S</math> and a conductor of <math>G=0.2S</math> are connected to a current source of 10 amperes. Determine the branch currents and plot the complete phasor diagram.</p>	10	CO6	L3	1.4.1
7b	<p>Find the input impedance of the circuit in Fig.7(b). Assume that the circuit operates at <math>\omega = 50</math> rad/s.</p>	10	CO6	L3	1.4.1



Q.No.	Questions	Marks	CO	BL	PI Code
8a	The impedance in each phase of a three phase 440v delta system comprises 5 ohms resistance in parallel with a 5 ohms capacitive reactance. Calculate the phase and line currents and the total power consumed .Draw the phasor diagram.	10	CO7	L3	1.4.1
8b	A three phase four wire system with line voltage of 400 v, 50 Hz supply has a star connected load of $Z_R= 10 L0^0$ ohms, $Z_Y=15L30^0$ ohms, $Z_B=6-j5$ ohms. Obtain the line currents and the current in the neutral conductor. Calculate the total power drawn. Draw the phasor diagram.	10	CO7	L3	1.4.1

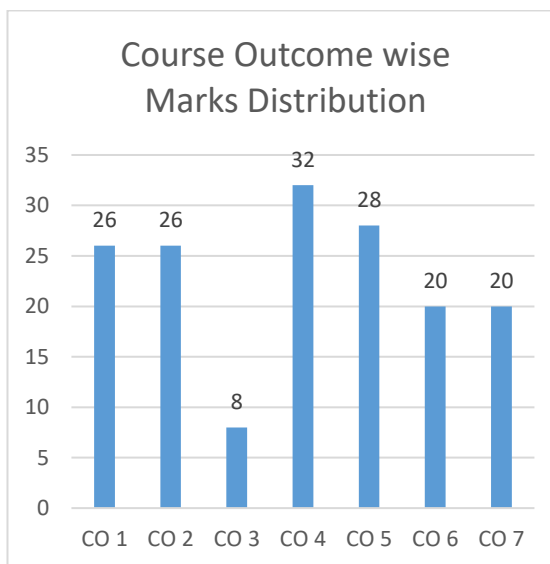
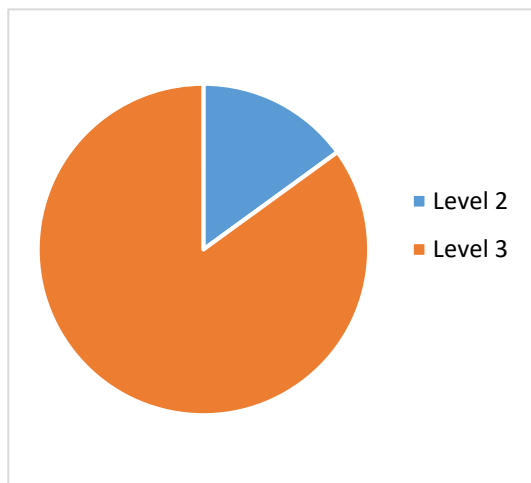

**BL – Bloom’s Taxonomy Levels (1- Remembering, 2- Understanding, 3 – Applying, 4 – Analysing, 5 – Evaluating, 6 - Creating)**

**CO – Course Outcomes**

**PO – Program Outcomes; PI Code – Performance Indicator Code**

## Course Name: Linear Control Systems

### Course Outcomes (CO):

At the end of the course the student is able to:

1. Develop the transfer function and block diagram/signal flow graph model of electrical/electronic /electro-mechanical systems.
2. Analyze the control system performance using time-domain approach and validate through simulations.
3. Analyze the absolute/related stability of a given control system by employing Routh-Hurwitz criterion.
4. Design PI/PD/PID controllers for a given plant by Zeigler-Nichol's and Pole placement techniques.
5. Apply known techniques to reshape the frequency response of a given control system in the form of polar plot/Bode plot, determine response specifications and validate through simulations.
6. Apply known techniques to obtain root locus of a given control system to determine the response specifications as function of given control parameter and validate through simulations.

**Model Question Paper**  
**Course : Linear Control Systems**

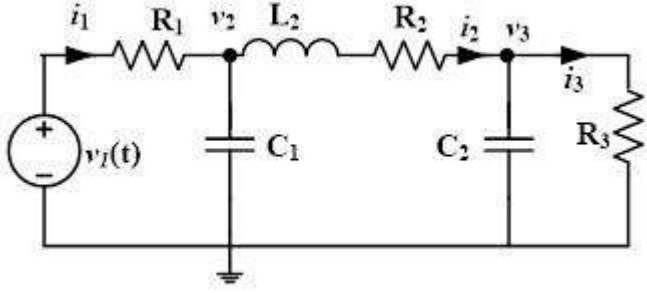
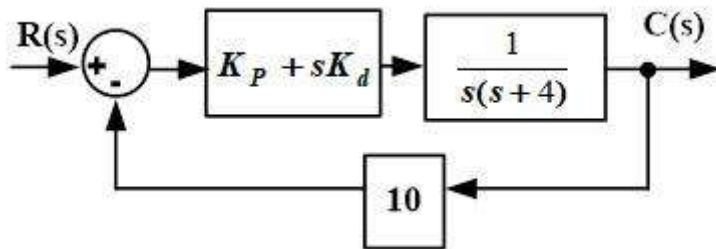
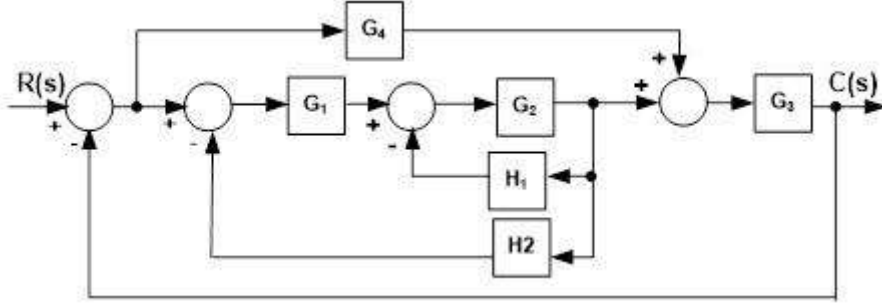
Q.No.	Questions	Marks	CO	BL	PO	PI Code
1a	<p>For the electrical circuit of Fig., deduce the model equations and hence represent by signal-flow graph with <math>v_1</math> (input), <math>v_2</math>, <math>v_3</math>, <math>i_1</math>, <math>i_2</math> and <math>i_3</math> (output) as variables.</p> 	10	CO1	L3	13	13.1.1
1b	<p>In industrial manufacturing certain robot arm is required to control the position of the end piece. Fig.1b shows the model of a closed loop position control system where the controller gains <math>k_p</math> and <math>k_d</math> are to be determined so as to satisfy the following specifications (i) Closed loop poles placed at <math>(-3.6 \pm j\beta)</math> (ii) Peak-time=0.65 sec. From the above descriptions (i) Identify the design specifications in terms of damping ratio (<math>\zeta</math>) and angular frequency (<math>\omega_n</math>)(ii)Deduce relations for <math>K_p</math> and <math>K_d</math> in terms of <math>\zeta</math> and <math>\omega_n</math> (iii) required gain settings (iv) Peak overshoot and settling time for these settings.</p> 	10	CO2	L3	2	2.1.2
2a	<p>Assuming under-damped unit step response of a second order control system, deduce expressions for peak-time and rise time. For a negative feedback control system, <math>G(s) = (10s+72)/s(2s+6)</math> and <math>H(s)=1</math>. Determine the peak overshoot, settling time and static error constants <math>K_p</math>, <math>K_v</math> and <math>K_a</math>.</p>	10	CO2	L3	13	13.1.1
2b	<p>For the block-diagram shown in Fig., obtain the signal flow graph and determine the T.F <math>C(s)/R(s)</math> by applying Mason's gain formula.</p> 	10	CO1	L3	13	13.1.1
3a	<p>First order field circuit model of a DC Generator is shown below where, <math>R_f=50</math>, <math>R_s=1</math> and <math>L_f=2.0</math>. (i) If <math>K=0.2</math>, obtain an expression for unit step output response by selecting gain <math>K_A</math> for zero steady-state error. (ii) If gain <math>K_A</math> is varied from 80 to 120 in steps of 10, determine the values of gain <math>K</math> that give time constant <math>\leq 0.005</math> sec and plot in the parameter plane (<math>K_A</math>, <math>K</math>) marking different regions of time constants. Also compute the corresponding steady-state error for unit step input and analyze the effect of <math>K_A</math> variations on it.</p>	10	CO1	L3	13	13.1.1

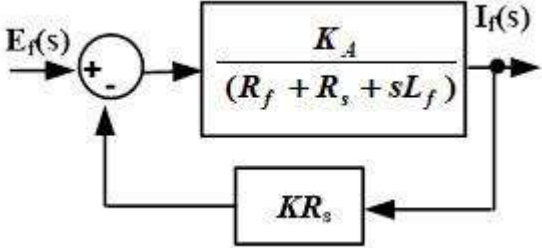
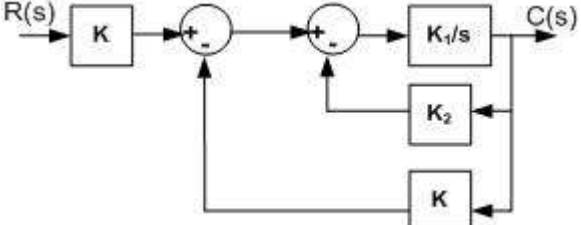
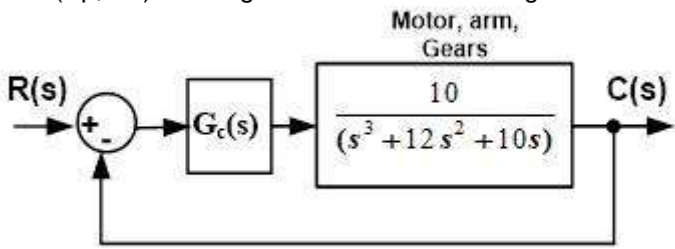
Q.No.	Questions	Marks	CO	BL	PO	PI Code
						
3b	<p>The depth control system of a submersible vehicle is shown in fig. below, where <math>K=0.5</math> (i) If <math>K_2=0.5</math> and gain <math>K_1</math> has limits <math>5 \leq K_1 \leq 20</math>, obtain the unit step response with <math>K_1</math> selected for fasted response.(ii) If gain <math>K_1</math> is varied from 1.0 to 7.0 in steps of 1.0, determine the gain <math>K_2</math> values that give time constant <math>\leq 0.1</math> and plot in the parameter plane <math>K_1 - K_2</math>. Also compute the corresponding equivalent gain (<math>K_e</math>) and steady-state errors and comment on the effect of <math>K_1</math> variations on the steady-state error.</p> 	10	CO2	L2	13	13.1.1
4a	<p>All elements in a row of Routh array are zero. What this indicates? How to overcome this situation? For a negative feedback control system, <math>G(s)=(K-2)/s(s^2+s+1)</math> and <math>H(s)=1/(s+5)</math>. By applying RH criterion, determine the range of gain <math>K</math> over which the closed loop system is absolutely stable. Also investigate the stability and number of roots in RHS of <math>s</math>-plane when <math>K=10</math> and <math>K=0.5</math>.</p>	10	CO3	L3	13	13.1.1
4b	<p>For a simplified model of DC generator voltage control system, <math>G_p(s)=1/(1+s)(2+s)</math> and <math>H(s)=1</math>. Design PID controller assuming <math>K_i=0.1</math> so as to place two dominant closed loop poles at <math>(-3 \pm j4)</math>.</p>	10	CO4	L3	3	3.2.2
5a	<p>The open loop T.F of a control system is <math>G(s)H(s)=10/s(s+1)(s+5)</math>. Sketch the approximate polar plot and analytically determine the gain margin.</p>	10	CO5	L2	13	13.1.1
5b	<p>Figure shows the model of the control system for one joint of a robot arm. The controller is a PD given as. Now it is required to determine the combinational values of <math>K_p</math> and <math>K_d</math> (both positive) for which the closed loop system is absolutely stable. In this respect (i) By applying RH criterion, deduce an expression for limiting value of <math>K_d</math> as a function of <math>K_p</math> (ii) If <math>K_p</math> is varied, determine the corresponding limiting value of <math>K_d</math> and plot in the parameter plane (<math>K_p, K_d</math>) marking stable and unstable regions.</p> 	10	CO3	L3	2	2.4.1
6a	<p>The open loop T.F of a control system is <math>G(s)H(s)=10/s(1+2s)</math>. Obtain the approximate polar plot and analytically determine the phase margin</p>	10	CO5	L3	13	13.1.1

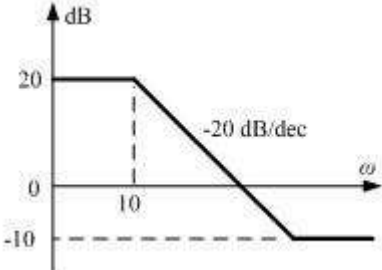
Q.No.	Questions	Marks	CO	BL	PO	PI Code
6b	For a simplified model of a synchronous generator excitation control system, $G_p(s)=0.8/(1+3s)(1+30s)$ and $H(s)=1/(1+10s)$ . Design PI and PID controllers using Zeigler-Nichol's tuning approach. Determine ultimate gain and time period using RH criterion	10	CO4	L3	3	3.2.2
7a	Briefly explain the procedure to compute gain and phase margins from Bode plot. For the Bode magnitude plot shown, determine Transfer function and phase margin. 	10	CO5	L3	13	13.1.1
7b	Sketch the asymptotic Bode magnitude plot and phase plot for the open loop transfer function $G(s)H(s)=(1+2s)(1+0.1s)/s(s+0.5s)$	10	CO5	L3	13	13.1.1
8a	Briefly explain the angle criterion of root locus technique. With an example, list the rules to construct the root locus diagram.	10	CO6	L2	13	13.1.1
8b	Show that the complex part of the root locus of $G(s)H(s)=K(s+2)/(s^2+2s+3)$ is a circle	10	CO6	L3	13	13.1.1

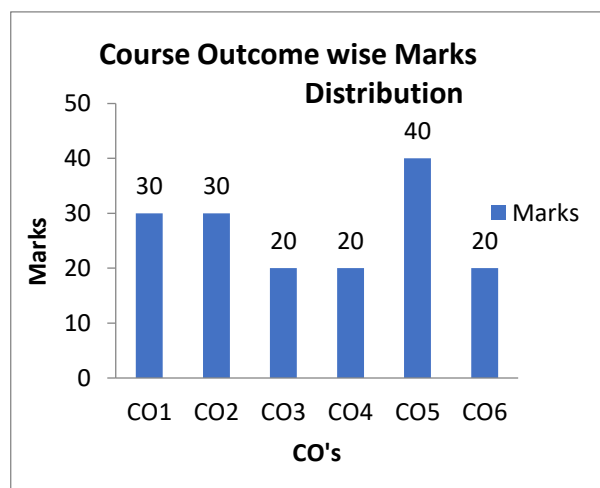
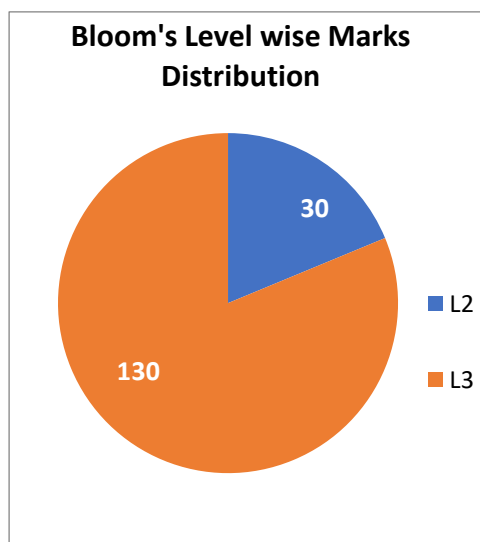

**BL – Bloom's Taxonomy Levels (1- Remembering, 2- Understanding, 3 – Applying, 4 – Analysing, 5 – Evaluating, 6 - Creating)**  
**CO – Course Outcomes**  
**PO – Program Outcomes; PI Code – Performance Indicator Code**

## Course: Analog Electronics Circuits

### Course Outcomes (COs):

1. Infer the terminal behavior of the devices such as Junction Diode, BJT & MOSFET, also identify the region of operation with its equivalent circuit model.
2. Identify the need for small signal operation and derive the small signal performance parameters of the device for amplification by relating design variable to the device parameters.
3. Outline and parse the performance parameters of various feedback topologies & large signal amplifiers.

**Model question paper for Analog Electronics Circuits**

Q.No.	Questions	Marks	CO	BL	PO	PI
1a	The input waveform available is a square waveform of amplitude 5V and frequency 1kHz. Using appropriate diode circuit, modify the amplitude of the waveform suitably retaining same value of frequency. Use this waveform to trigger a digital circuit. Justify your answer.	7	CO1	L3	2	2.1.2
1b	Design a voltage divider bias BJT circuit to have $V_{CE} = V_E = 5V$ and $I_C = 5mA$ , when the supply voltage is 15V. Assume transistor $h_{FE} = 100$ .	7	CO1	L3	1	1.4.1
1c	The circuit given below consists of a non-linear diode. Determine $V_B$ (voltage across $5k\Omega$ ) using small signal model of diode.	6	CO1	L3	1	1.4.1
2a	Design an appropriate diode circuit for the transfer function given below. Analyze the circuit and draw input output waveforms.	7	CO1	L3	3	3.4.1
2b	The input voltage $v_i(t)$ to the two level clipper shown in Fig.2a varies linearly from 0 to 150 V. Sketch the transfer characteristics assuming diodes are ideal	7	CO2	L3	1	1.4.1

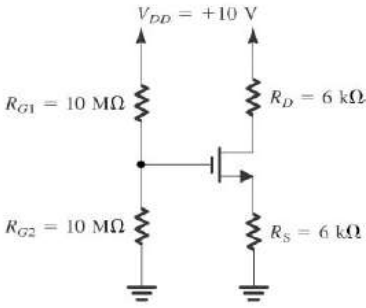
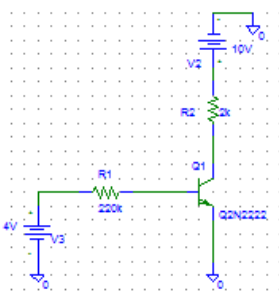
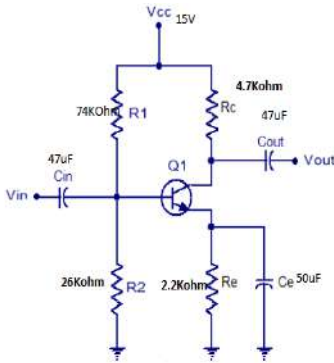
<p>2c</p>	<p>Determine voltages at all nodes and the currents through all branches. Let <math>V_t = 1V</math> and <math>k'_n \left(\frac{W_n}{L_n}\right) = 1mA/V^2</math>. Neglect channel length modulation.</p>	<p>6</p>	<p>CO1</p>	<p>L3</p>	<p>1</p>	<p>1.4.1</p>
						
<p>3a</p>	<p>Calculate the base, collector and emitter currents and <math>V_{CE}</math> for a common emitter circuit given below. Also determine the transistor power dissipation.</p>	<p>7</p>	<p>CO1</p>	<p>L2</p>	<p>1</p>	<p>1.4.1</p>
						
<p>3b</p>	<p>Draw input and output characteristics of nMOS for increasing value of length and oxide thickness.</p>	<p>6</p>	<p>CO1</p>	<p>L3</p>	<p>1</p>	<p>1.4.1</p>
<p>3c</p>	<p>Determine <math>Z_i</math>, <math>Z_o</math>, <math>A_v</math> and <math>Q(V_{CEQ}, I_{CQ})</math> of the circuit given below. Assume <math>h_{fe} = 180</math>, <math>h_{ie} = 2.7k\Omega</math> and <math>h_{oe} = 25\mu mho</math></p>	<p>7</p>	<p>CO2</p>	<p>L2</p>	<p>1</p>	<p>1.4.1</p>
						
<p>4a</p>	<p>For the circuit given below, find the labelled node voltages. The nMOS transistors have <math>V_t = 1V</math> and <math>k'_n \left(\frac{W_n}{L_n}\right) = 2mA/V^2</math>. Neglect channel length modulation.</p>	<p>6</p>	<p>CO1</p>	<p>L3</p>	<p>1</p>	<p>1.4.1</p>

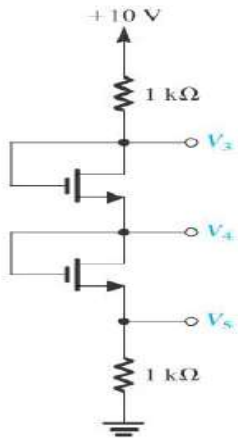
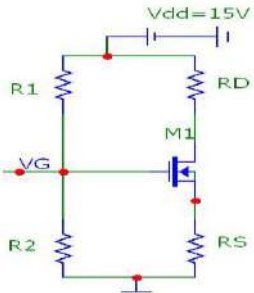
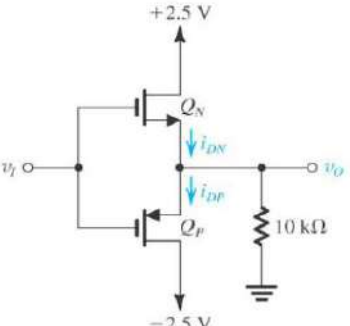

						
4b	<p>For a CD amplifier, find the expression for <math>R_i, A_{vo}, A_v, R_{out}</math> highlighting the effect of <math>r_0</math>.</p>	6	CO2	L3	1	1.4.1
4c	<p>Design the circuit shown below to establish a dc drain current of 0.5mA. The MOSFET is specified to have <math>V_t = 1V</math> and <math>k'_n \left(\frac{W_n}{L_n}\right) = 1mA/V^2</math>. For simplicity neglect the channel length modulation. <math>V_{DD} = 15V</math> calculate the percentage change in the value of Id obtained when the MOSFET is replaced with having same <math>k'_n \left(\frac{W_n}{L_n}\right)</math> but <math>V_t = 1.5V</math></p> 	8	CO2	L3	3	3.4.1
5a	<p>The NMOS and PMOS transistor in the circuit shown below are matched with <math>k'_n \left(\frac{W_n}{L_n}\right) = k'_p \left(\frac{W_p}{L_p}\right) = 1mA/V^2</math> and <math>V_{tn} = -V_{tp} = 1V</math>. Assuming <math>\lambda = 0</math> for both the devices. Find the drain currents and <math>i_{DN}, i_{DP}</math> as well as voltage <math>v_o</math> for i) <math>v_i = 0V</math> ii) <math>v_i = -2.5V</math> iii) <math>v_i = +2.5V</math></p> 	10	CO2	L3	1	1.4.1
5b	<p>A student is assigned a task to design an amplifier circuit to amplify an audio signal. The circuit chosen by</p>	10	CO2	L3	2	2.1.2

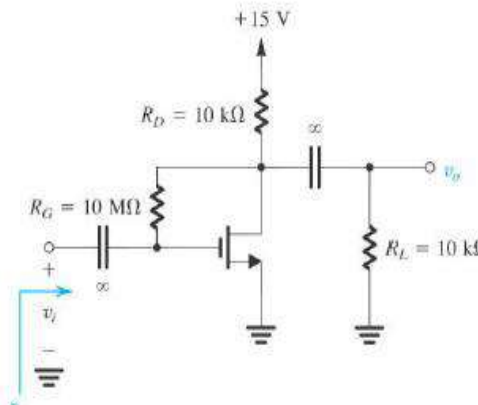
	<p>the student is given below. Identify the type of biasing circuit used. Determine its small signal voltage gain, input resistance and the largest allowable input signal. The transistor has <math>V_t = 1.5V</math>, <math>k'_n \left(\frac{W_n}{L_n}\right) = 0.25 \text{ mA/V}^2</math>, <math>V_A = 50V</math>. State the assumptions.</p> 					
6a	Using two transistors Q1 and Q2 having equal lengths but different widths related by $W_2/W_1 = 5$ . Design the circuit of basic current mirror to obtain $I=0.5\text{mA}$ . Let $V_{DD} = 5V$ , $K_n(W/L)_1 = 0.8\text{mA/V}^2$ , $V_t = 1.5V$ and $\lambda=0$ . Find the required value of R? What is voltage at the gates of Q1 and Q2? What is the lowest voltage allowed at the drain of Q2 while Q2 remains in the saturation region?	7	CO2	L2	1	1.4.1
6b	Draw the small signal model for common gate amplifier and derive the expression for input, output impedance and voltage gain.	7	CO2	L2	1	1.4.1
6c	An NMOS transistor has $\mu_n c_{ox} = 60\mu\text{A/V}^2$ , $\frac{W}{L} = 40$ , $V_t = 1.5V$ and $V_A = 15V$ (a) find $g_m$ and $r_0$ when $V_{GS}=1.5\text{v}$ (b) find $g_m$ and $r_0$ when $I_D=0.5\text{mA}$	6	CO2	L2	1	1.4.1
7a	An amplifier with negative feedback has a voltage gain of 120. It is found that without feedback, an input signal of 60mV is required to produce a particular output. Find the $A_v$ and $\beta$ of the amplifier.	6	CO3	L2	1	1.4.1
7b	Discuss the general characteristics of a negative feedback amplifier.	6	CO3	L2	1	1.4.1
7c	Derive an expression for input and output resistance of a voltage shunt feedback amplifier, and explain.	8	CO3	L2	1	1.4.1
8a	Explain the classification of power amplifiers based on the location of the operating point with neat diagrams.	6	CO3	L2	1	1.4.1
8b	Explain the operation of transformer coupled amplifier with neat circuit diagram and derive the expressions for maximum efficiency	6	CO3	L2	1	1.4.1

8c	A class B power amplifier is delivering an output voltage of 10 volts peak to an $8 \Omega$ load, if the DC power supply is 30 volts; calculate i) DC power input. ii) AC power delivered to the load iii) Conversion efficiency iv) Power dissipated in the collector of each transistor.	8	CO3	L3	1	1.4.1
----	--	---	-----	----	---	-------

### Bloom's level wise marks distribution

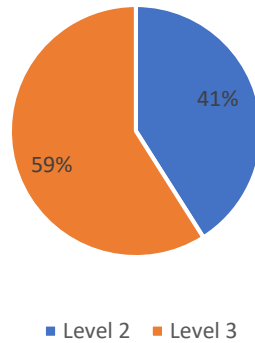

### Course Outcome Wise Marks Distribution

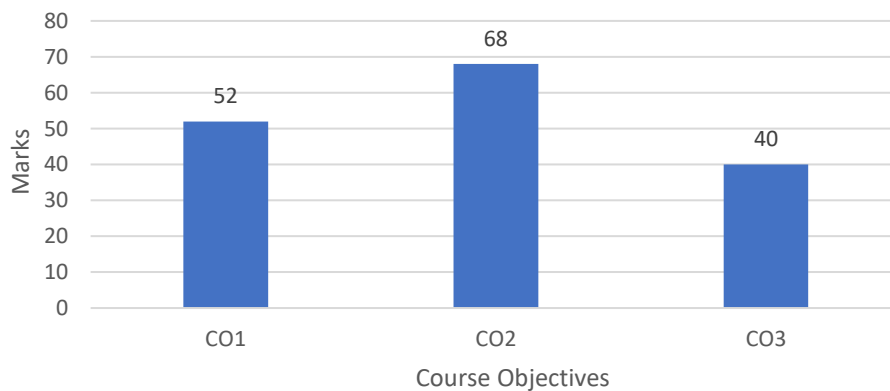

## Course: Digital Signal Processing

### Course Learning Objectives:

1. Represent the given signal mathematically, and apply it for system analysis
2. Represent LTI systems using differential and difference equations and hence analyze the same
3. Characterize the discrete time signal in frequency domain using Fourier series and Fourier transform
4. Apply DFT techniques for applications like spectral analysis, linear filtering.
5. Apply FFT techniques for applications like, linear filtering and Correlation.
6. Design digital IIR and FIR filters for the given specification
7. Explore the basic concepts of Signals and Systems, and Digital Signal Processing using computational tool.

### Model question paper for Digital Signal Processing

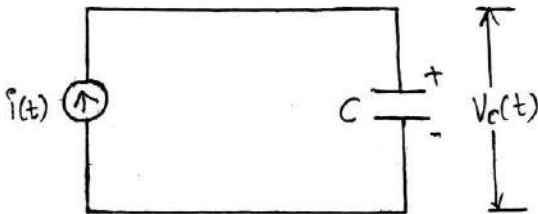
Q.No.	Questions	Marks	CO	BL	PI Code
1a	<p>Let <math>x(t)</math> be a continuous time signal, and let <math>y_1(t) = x(2t)</math> and <math>y_2(t) = x(t/2)</math>. The signal <math>y_1(t)</math> represents a speeded up version of <math>x(t)</math> similarly <math>y_2(t)</math> represents a slowed down version of <math>x(t)</math>. Consider the following statements</p> <ol style="list-style-type: none"> <li>i) If <math>x(t)</math> is periodic, then <math>y_1(t)</math> is periodic</li> <li>ii) If <math>y_2(t)</math> is periodic, then <math>x(t)</math> is periodic</li> </ol> <p>For each of these statements, determine whether it is true, and if so, determine the relationship between the fundamental periods of the two signals considered in the statement. If the statement is not true, produce a counterexample to it.</p>	8	CO1	L3	1.4.1
1b	<p>Consider the capacitor circuit shown in fig below. Let input <math>x(t) = i(t)</math> and output <math>y(t) = v_c(t)</math></p> <ol style="list-style-type: none"> <li>i) Find the input-output relationship</li> <li>ii) Determine the system is a) memory less, b) Causal c) Linear d) Stable e) Time-invariant.</li> </ol> 	6	CO2	L3	1.4.1
1c	<p>Obtain the direct form-I, direct form-II for the following system which is represented in difference equation form.</p> $y(n) = -0.1y(n-1) + 0.2y(n-2) + 3x(n) + 3.6x(n-1) + 0.6x(n-2)$	6	CO2	L2	1.4.1
2a	<p>Classify the following signals according to whether they are (1) one or multi-dimensional (2) continuous time or discrete time and (3) analog or digital (amplitude). Justify</p> <ol style="list-style-type: none"> <li>i) Closing prices of utility stocks on New York Stock Exchange</li> </ol>	8	CO1	L3	1.4.1

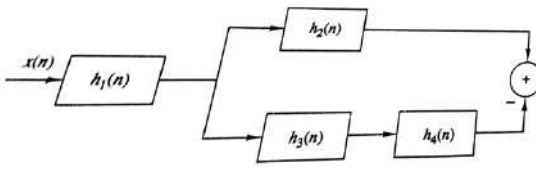
Q.No.	Questions	Marks	CO	BL	PI Code
	ii) A color movie iii) Position of the steering wheel of a car in motion relative to car's reference frame.				
2b	Consider the interconnection of LTI system shown in fig below, i) Express overall impulse response in terms of $h_1(n), h_2(n), h_3(n)$ and $h_4(n)$ with all intermediate steps ii) Determine $h(n)$ when $h_1(n) = \left\{ \begin{matrix} 1 & 1 & 1 \\ 2 & 4 & 2 \end{matrix} \right\}$ ;  $h_2(n) = h_3(n) = (n + 1)u(n); h_4(n) = \delta(n - 2)$	6	CO2	L3	1.4.1
2c	Sketch and label the following signals. i) $x(t) = -u(t + 3) + 2u(t + 1) - 2u(t - 1) + u(t - 3)$ ii) $y(t) = r(t + 2) - r(t + 1) - r(t - 1) + r(t - 2)$	6	CO1	L2	1.4.1
3a	An audio signal $s(t)$ generated by a loud speaker is reflected at two different walls with reflection coefficients $r_1, r_2$ . The signal $x(t)$ recorded by a microphone close to the loud speaker, after sampling, is $x(n) = s(n) + r_1s(n - k_1) + r_2s(n - k_2)$ . Where $k_1$ and $k_2$ are the delays of two echoes. Determine autocorrelation $r_{xx}(l)$ of the signal $x(n)$ .	8	CO2	L3	2.1.3
3b	Determine the total solution $y(n), n \geq 0$ to the difference equation $y(n) + a_1y(n - 1) = x(n)$ when $x(n)$ is a unit step sequence and $y(-1)$ is initial condition.	6	CO2	L2	1.4.1
3c	Show that any signal can be decomposed into an even and an odd component. Is the decomposition is unique? Illustrate your arguments using the signal $x(n) = \{2, 3, 4, 5, 6\}$	6	CO1	L2	1.4.1
4a	Given sequences $x_1[n] = \{1, 1, 2, 1\}$ $x_2[n] = \{1, 2, 3, 4\}$ find $x_3[n]$ such that $X_3(k) = X_1(k)X_2(k)$ using DFT and IDFT method.	10	CO4	L2	1.4.1
4b	For an instance digital audio has long input data sequence $x[n] = \{1, 2, -1, 2, 3, -2, -3, -1, 1, 1, 2, -1\}$ and $h[n] = \{1, 2\}$ which are running at a rate of 5Mbytes /min. With this high data rate, it is common for computers to have insufficient memory to simultaneously hold the entire signal to be processed. Suggest a method to process the data segment by segment so that computers with insufficient memory can also handle the long data sequence which are running at high speed.	10	CO4	L3	2.1.3

Q.No.	Questions	Marks	CO	BL	PI Code
5a	Determine Fourier series co-efficients of a periodic signal $x[n] = \{1,1,0,0\}$ with period $N=4$ also plot its magnitude and phase spectrum.	6	CO3	L2	1.4.1
5b	Compute circular convolution of the sequences $x[n] = \{1,2,3,1\}$ and $h[n] = \{4,3,2,2\}$ such that it is equivalent to linear convolution of the of the same sequences.	10	CO3	L3	1.4.1
5c	Find the Fourier Transform of $x(n) = \frac{1}{2}^{(n-1)}$ . If you have used any property while determining $X(k)$ , state it.	4	CO3	L2	1.4.1
6a	Compute IDFT of sequence $X[k] = \{7, -0.707 - j0.707, -j, 0.707 - j0.707, 1, 0.707 + j0.707, j, -0.707 + j0.707\}$ using Radix-2 decimation in frequency FFT algorithm. Keep track of all intermediate results and show them on butterfly diagram.	10	CO5	L3	1.4.1
6b	The impulse response of an LTI system is given by $h(n) = \delta(n) - \frac{1}{4}\delta(n - k_0)$ . To determine the impulse response $g(n)$ of the inverse system, an engineer computes the $N$ -point DFT, $N = 4k_0$ , of $h(n)$ and then defines $g(n)$ as the inverse DFT of $G(k) = \frac{1}{H(k)}$ , $k = 0, 1, 2, \dots, N - 1$ . Determine $g(n)$ and the convolution $h(n) * g(n)$ , and comment on whether the system with impulse response $g(n)$ is the inverse of the system with impulse response $h(n)$ .	10	CO4	L3	1.4.1
7a	Convert the analog filter whose transfer function is given by $H(s) = \frac{2}{(s+1)(s+2)}$ to digital filter using impulse invariance method. Assume $T=1$ sec	10	CO6	L2	1.4.1
7b	With the analysis of the Electrocardiogram (ECG) signal it is possible to predict heart problems or monitor patient recovery after a heart intervention. But The quality of biomedical signal is degraded mainly by many sources of noise so it is required to design a digital filter with Chebyshev approximation for the specifications $\alpha_p = 3dB$ , $\alpha_s = 16dB$ , $f_p = 1kHz$ , $f_s = 2kHz$ . to overcome degradation by improving ECG signal quality for quality clinical diagnosis.	10	CO6	L3	2.1.3
8a	Design a filter with frequency response $H_d(e^{-j\omega}) = \begin{cases} e^{-j3\omega}, & -\frac{\pi}{4} \leq \omega \leq \frac{\pi}{4} \\ 0, & \frac{\pi}{4} <  \omega  \leq \pi \end{cases}$ using Hanning window for $N=7$	10	CO6	L3	3.4.1
8b	Design an ideal Hilbert transformer with frequency response $H_d(e^{j\omega}) = \begin{cases} j, & -\pi \leq \omega \leq 0 \\ -j, & 0 \leq \omega \leq \pi \end{cases}$ using rectangular window for $N=11$	10	CO6	L3	3.4.1

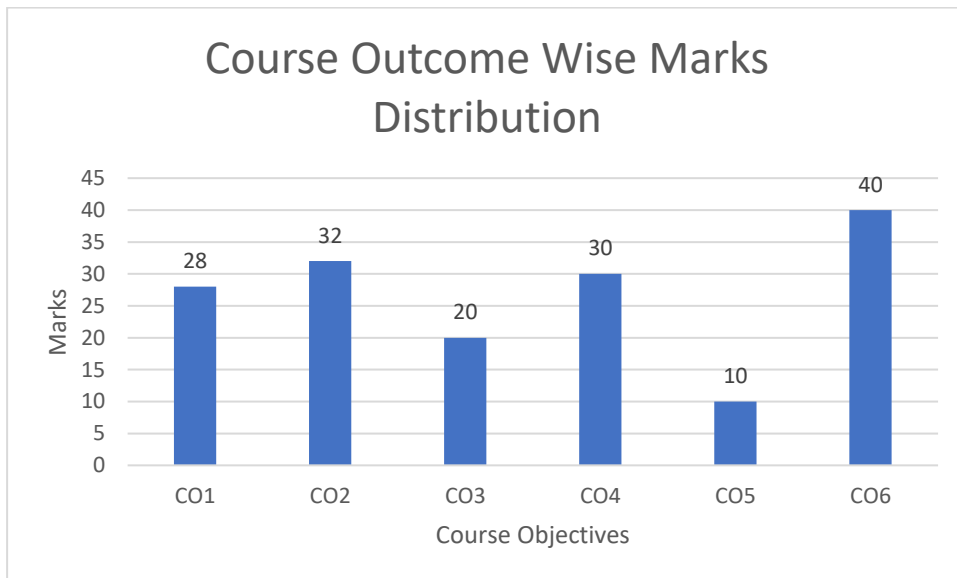
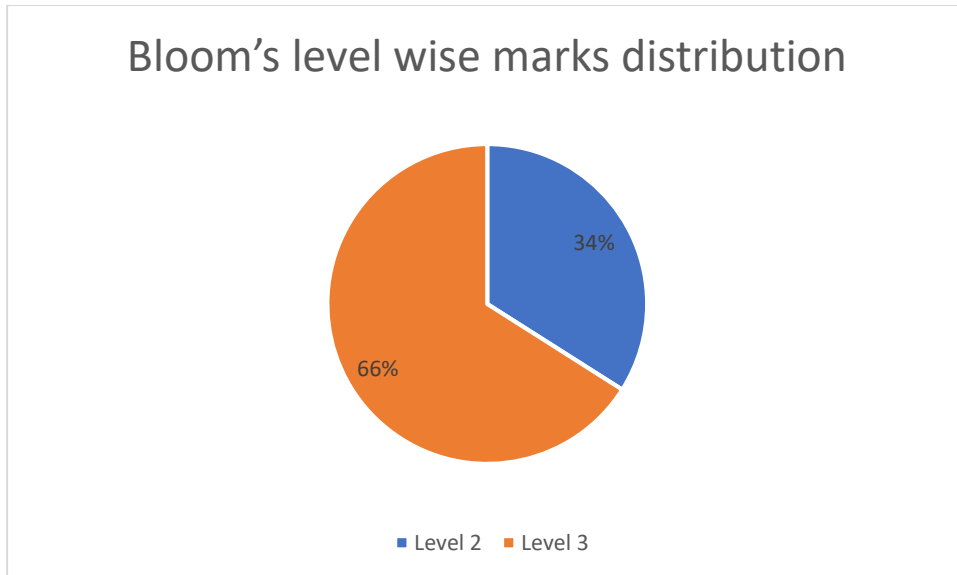

## Course Name: Power Electronics

### Course Outcomes

1. Apply basic volt-sec balance, amp-sec balance for inductors and capacitors present in a power converter so as to estimate output voltage and current of power converters
2. Design different dc-dc converters operating in continuous conduction mode for given specification of output voltage, output current and ripple voltage/current
3. Analyze square wave, PWM single phase and three phase voltage source inverters for output voltage amplitude and frequency control
4. Analyze single phase controlled rectifiers for R and RL load for both continuous and discontinuous conduction
5. Analyze single phase voltage controllers for R and RL load and explain static VAR control
6. Design MOSFET and IGBT gate drive circuits, BJT drive circuits, transistor and thyristor snubber circuits as well as cooling requirements for power semiconductor devices

### Model Question Paper

#### Course: Power Electronics

Q.No	Question	Marks	CO	BL	PI Code
1a	State and prove ampere-second balance and volt-second balance. Also, establish the relationship between input voltage and output voltage for buck and boost type DC-DC converters by applying ampere-second balance to the capacitor.	10	2	L3	1.4.1
1b	A non-sinusoidal periodic voltage has a Fourier series of $v(t) = 10 + 20 \cos(2\pi 60t - 250) + 30 \cos(4\pi 60t + 200)$ V. This voltage is connected to a load that is a $5\Omega$ resistor and a 15-mH inductor connected in series. Determine the power absorbed by the load.	10	1	L2	1.4.1
2a	Show that rms value of a sinusoid is the peak value divided by $\sqrt{2}$ . Give two examples to show that this is generally not the case for other periodic waveforms.	10	1	L2	1.4.1
2b	A buck converter has an input voltage that varies between 50 and 60 V and a load that varies between 75 and 125 W. The output voltage required by load is 20 V with allowable ripple of 1%. For a switching frequency of 100 kHz, Design system components to provide for continuous current for every operating possibility.	10	2	L3	3.1.6
3a	An electric resistance space heater rated at 1500 W for a voltage source of $v(t) = 120\sqrt{2} \sin(2\pi 60t)$ V has a thermostatically controlled switch. The heater periodically switches on for 5 min and off for 7 min. Determine (i) the maximum instantaneous power, (ii) the average power over the 12-min cycle, and (iii) the electric energy converted to heat in each 12 min cycle. A non-sinusoidal periodic voltage has a Fourier series of	10	1	L3	2.1.3



Q.No	Question	Marks	CO	BL	PI Code
3b	With necessary equivalent circuit diagrams and relevant waveforms of a SEPIC converter in CCM, derive expressions for voltage gain and current gain.	10	2	L2	1.4.1
4a	Explain how amplitude and harmonics are controlled in a single phase voltage source inverter simultaneously using relevant waveforms. Also derive an expression for the rms value of output voltage in terms of dc link voltage and delay angle.	10	3	L2	1.4.1
4b	A certain situation requires that either 160 or 75 W be supplied to a 48 V battery from a 120 V rms 60 Hz ac source. There is a two-position switch on a control panel set at either 160 or 75. Design a single circuit to deliver both values of power, and specify what the control switch will do. Specify the values of all the components in your circuit. The internal resistance of the battery is 0.1 $\Omega$ .	10	4	L3	2.1.3
5a	Design an inverter that has a PWM output across an RL series load with $R=10\Omega$ and $L=20\text{mH}$ . The fundamental frequency of the output voltage must be 120 V rms at 60Hz, and the total harmonic distortion of the load current must be less than 8 percent. Specify the dc input voltage, the amplitude modulation ratio $m_a$ , and the switching frequency (carrier frequency). State the assumptions and approximations clearly involved in design process	10	3	L3	3.1.6
5b	Show that the controlled half-wave rectifier and full wave rectifier with a resistive load have the power factor of $pf_{HW} = \sqrt{\frac{1}{2} - \frac{\alpha}{2\pi} + \frac{\sin 2\alpha}{4\pi}}$ and $pf_{FW} = \sqrt{1 - \frac{\alpha}{\pi} + \frac{\sin 2\alpha}{2\pi}}$ Also, explain the significance of power factor in rectifier circuits.	10	4	L2	1.4.1
6a	The full-bridge inverter has a switching sequence that produces a square wave voltage across a series RL load. The switching frequency is 60 Hz, $V_{dc} = 100\text{ V}$ , $R=10\ \Omega$ , and $L=25\text{ mH}$ . Determine (a) an expression for load current, (b) the power absorbed by the load, and (c) the average current in the dc source.	10	3	L2	1.4.1
6b	Design a circuit that will deliver 100 W to a 48 V dc source from a 120 V rms 60 Hz ac source. Give alternative circuits that could be used to satisfy the design specifications, and give reasons for your selection.	10	4	L3	3.1.6
7a	Explain application of ac voltage controller to maintain a unity power factor for varying load VAR requirements	08	5	L2	1.4.1
7b	Light-dimmer for ambient lighting consists of incandescent light bulb for use in USA (with 120 V rms, 50Hz). Bulb is measured to consume 500 W of power for particular lighting condition. Design suitable circuit to meet the requirements. Assume the bulb to be purely resistive with resistance of 15 ohms.	12	5	L3	3.1.6
8a	With a neat circuit diagram and waveforms, explain low side driver circuits for MOSFET and IGBT.	08	6	L2	1.4.1

Q.No	Question	Marks	CO	BL	PI Code
8b	<p>For a BJT in its high switching frequency application of 50kHz, spike of 1A at the turn-on is observed. The current reduces to 0.2 A post switching transients in the on state. Design a circuit to cater to driving requirements for BJT for high switching application.</p> <p>(Design hints: Assume i) <math>V_{BE}=0.9V</math>, ii) Control pulse input of 0-15V with duty ratio of 50%)</p>	12	6	L3	3.1.6

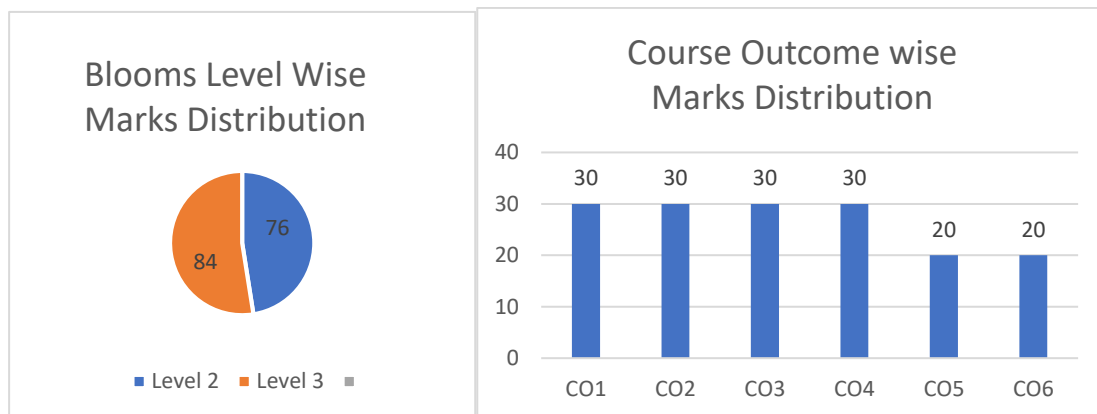

# Electronics & Communications Engineering

## Model Question Papers

### For Undergraduate Program

The model question papers are suggestive blueprints. The primary aim of these question papers is to bring clarity about the process of connecting questions to performance indicators and hence to course outcomes. Further, these question papers demonstrate how bloom's taxonomy can be used to understand the quality of question papers and their effectiveness in assessing higher order abilities. The structure of question papers, number of questions, choices given, time given for examination etc., can vary based on the practices of the University or college.

# Table of Contents

<b>Name of Course</b>	<b>Page No.</b>
1. Analog Electronics Circuits	ECE1-ECE6
2. Automotive Electronics	ECE7- ECE10
3. CMOS VLSI Circuits	ECE11- ECE14
4. Digital Circuits	ECE15- ECE18
5. Linear Integrated Circuits	ECE19- ECE23
6. Operating System and Embedded Systems	ECE24- ECE27
7. Signals and Systems	ECE28- ECE31

## Course Name: Analog Electronics Circuits

Semester: III (ECE)

Course Outcomes (CO):

1. Infer the terminal behaviour of the devices such as Junction Diode, BJT & MOSFET, also identify the region of operation with its equivalent circuit model.
2. Identify the need for small signal operation and derive the small signal performance parameters of the device for amplification by relating design variable to the device parameters.
3. Outline and parse the performance parameters of various feedback topologies & large signal amplifiers.
4. Develop the basic analog functional block for an application, and verify its functionality using a suitable ECAD tool.

**Model Question Paper**  
**Total Duration (H: M): 3:00**  
**Course: Analog Electronic Circuits**  
**Maximum Marks: 100**

Q.No	Questions	Marks	CO	BL	PI
<b>UNIT I</b>					
1a	Design the following circuit to provide the output voltage $V_0$ of 3.8V. Assume that the diodes have 0.7V drop at 1mA and $\Delta V=0.1V/\text{decade}$ change in current. <div style="text-align: center;"> </div>	7	1	3	2.1.2
1b	Derive the DC bias currents $I_B$ , $I_C$ , $I_E$ , $V_{CE}$ and $S_{ICO}$ for voltage divider biasing using BJT. Draw the DC load line and locate the operating point. With the help of sequence of events show how the operating point is stabilized.	7	1	2	1.4.2
1c	Design a circuit using suitable components to obtain the following input- output characteristics and explain the working of the same. <div style="text-align: center;"> </div>	6	1	3	2.1.2
2a	The input voltage $V_i$ to the circuit shown below varies linearly from 0 to 150V. Sketch the output waveform. Assume diodes as ideal.	7	1	3	2.1.2

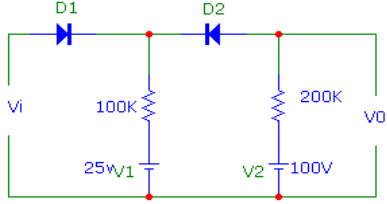
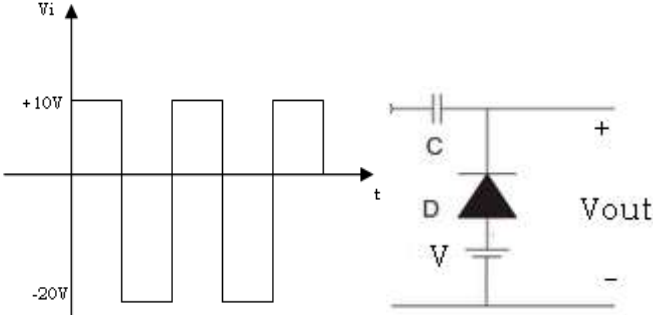
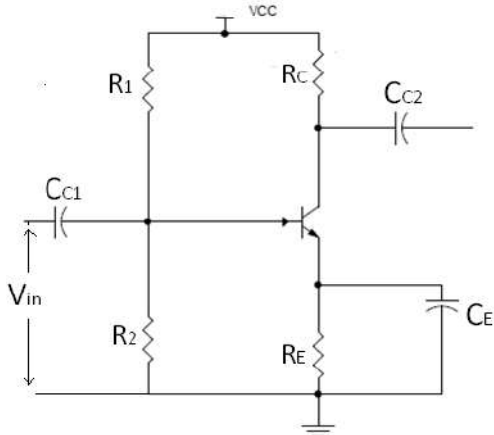
Q.No	Questions	Marks	CO	BL	PI
					
2b	List different diode models. Explain any three models in detail.	7	1	2	1.4.2
2c	<p>Identify the circuit and plot the output waveform if the input signal <math>V_i</math> shown below is applied. Given <math>C=1\mu\text{F}</math>, <math>V=5\text{V}</math>, cut in voltage of the diode <math>V_Y=0.7\text{V}</math></p> 	6	1	3	2.1.2
3a	<p>Identify the following amplifier configuration and determine the DC bias voltages and currents to locate the Q-point. Compute various amplifier parameters when <math>R_1=68\text{k}\Omega</math>, <math>R_2=12\text{k}\Omega</math>, <math>V_{CC}=18\text{V}</math>, <math>R_C=2.2\text{k}\Omega</math>, <math>R_E=1.2\text{k}\Omega</math>, <math>h_{fe}=180</math>, <math>h_{ie}=2.75\text{k}\Omega</math>, <math>h_{oe}=25\mu\text{mho}</math>.</p> 	7	2	3	2.1.2
3b	Prove that $r_d = nV_T/I_D$ for a small signal diode model with necessary circuit diagram and transfer characteristics curve.	7	1	2	1.4.2
3c	Draw the steady state output waveform for the following circuit indicating maximum and minimum value of the output. Given $R_f=2\text{M}\Omega$ , $R_f=0\Omega$ cut-in voltage of diode = $0\text{V}$ , input voltage is $5\text{KHz}$ square wave varying between $+10\text{V}$ and $-10\text{V}$ .	6	1	3	2.1.2

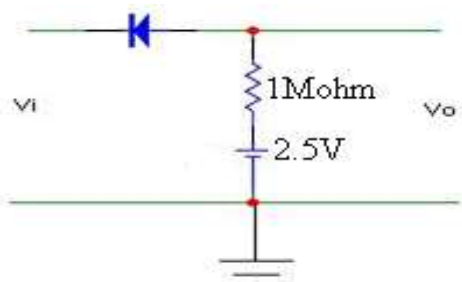
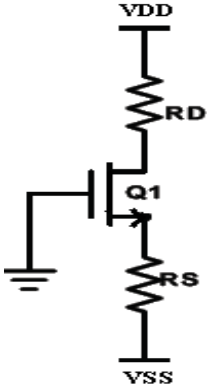
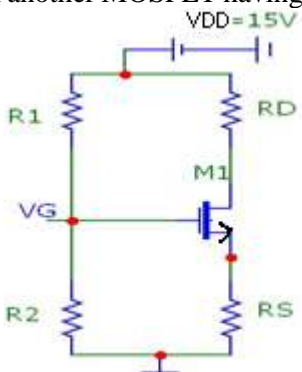
Q.No	Questions	Marks	CO	BL	PI
					
<b>UNIT II</b>					
4a	<p>Find the values of circuit elements shown below for given current <math>I_D</math> of 0.4mA, <math>V_D=0.5V</math>, <math>V_t=0.7V</math>, <math>\mu_n C_{ox}= 100mA/V^2</math>, <math>L=1\mu m</math> &amp; <math>W=32\mu m</math> <math>V_{DD}=-V_{SS}=2.5V</math>. Neglect channel length modulation effect.</p> 	7	2	3	1.4.2
4b	<p>Design the circuit elements as shown in below figure to establish a DC drain current of 0.5mA. The NMOS is specified to have <math>V_t=1V</math> and <math>k_n'(W/L)=1mA/V^2</math> and <math>\lambda=0</math>. Calculate the percentage change in the value of <math>I_D</math> obtained when the MOSFET is replaced with another MOSFET having same <math>k_n'(W/L)</math> but <math>V_t=1.5V</math></p> 	7	2	3	2.1.2
4c	<p>Draw the DC equivalent, AC equivalent and small signal equivalent model for common gate amplifier and derive the expressions for input, output impedance and voltage gain.</p>	6	2	3	1.4.1
5a	<p>Derive an expression for drain current <math>I_D</math> for NMOS in different regions of operation.</p>	7	1	3	1.4.2
5b	<p>Consider common source amplifier with constant current source biasing technique where <math>V_{DD}= -V_{SS}=15V</math>, current <math>I=0.5mA</math>, <math>R_G=4.7M\Omega</math>, <math>R_D=10K\Omega</math>, <math>V_t=1.5V</math> and <math>K_n'(W/L)=1mA/V^2</math>. Determine the Q-points and all the amplifier parameters assuming <math>V_A=75V</math>.</p>	7	2	3	1.4.2

Q.No	Questions	Marks	CO	BL	PI
5c	Using two transistors $Q_1$ and $Q_2$ having equal lengths but different widths related by $W_2/W_1 = 5$ . Design a circuit that replicates current and obtain $I=0.5mA$ . Let $V_{DD}=5V$ , $k_n'(W/L)_1 = 0.8mA/V^2$ , $V_t=1V$ and $\lambda=0$ . Find the required value of $R$ ? What is voltage at the gates of $Q_1$ and $Q_2$ ? What is the lowest voltage allowed at the drain of $Q_2$ while $Q_2$ remains in the saturation region?	6	2	3	2.1.2
6a	Explain the working of N-channel enhancement mode MOSFET with relevant diagrams.	7	1	2	1.4.2
6b	The NMOS transistors used in the following circuits have $V_t=1V$ , $\mu_n C_{ox} = 120 \mu A/V^2$ , $\lambda=0$ , $L_1=L_2=L_3=1\mu m$ . Find the equivalent values of gate widths for each of transistors to obtain voltage values as indicated in the figure and current of $120\mu A$ .	7	2	3	2.1.2
6c	A drain current of $115\mu A$ and drain voltage of $3.5V$ is to be developed across the MOSFET shown in below figure, obtain the value of $R$ to meet the requirement. Given $V_t = -0.7V$ , $V_{DD}=5V$ , $\mu_p C_{ox} = 60\mu A/V^2$ , $L=0.8\mu m$ and $\lambda=0$ . Determine the width of the channel.	6	2	3	2.1.2
<b>UNIT III</b>					
7a.	An amplifier with negative feedback has a voltage gain of 120. It is found that without feedback, an input signal of $60mV$ is required to produce a particular output. Find the $A_v$ and $\beta$ of the amplifier.	6	3	2	1.4.2
7b.	Discuss the general characteristics of a negative feedback amplifier.	6	3	2	1.4.2

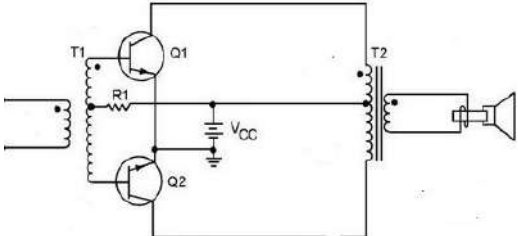

Q.No	Questions	Marks	CO	BL	PI
7c.	Derive an expression for input and output resistance of a voltage shunt feedback amplifier, and explain.	8	3	3	1.4.2
8a.	Explain the classification of power amplifiers based on the location of the operating point with neat diagrams.	6	3	2	1.4.2
8b.	A class B power amplifier is delivering an output voltage of 10 volts peak to an $8 \Omega$ load, if the DC power supply is 30 volts; calculate i) DC power input. ii) AC power delivered to the load iii) Conversion efficiency iv) Power dissipated in the collector of each transistor.	6	3	3	1.4.2
8c.	A loud speaker with an 8 ohm input resistance requiring a power of 0.5 W is to be driven by the following amplifier configuration. $V_{CC}$ is a 9V battery, and the identical transistors have $V_{CEsat} = 0.5 \text{ V}$ and $I_{BEO}=0$ . Select a suitable turn's ratio for output transformer. 	8	3	3	2.1.2

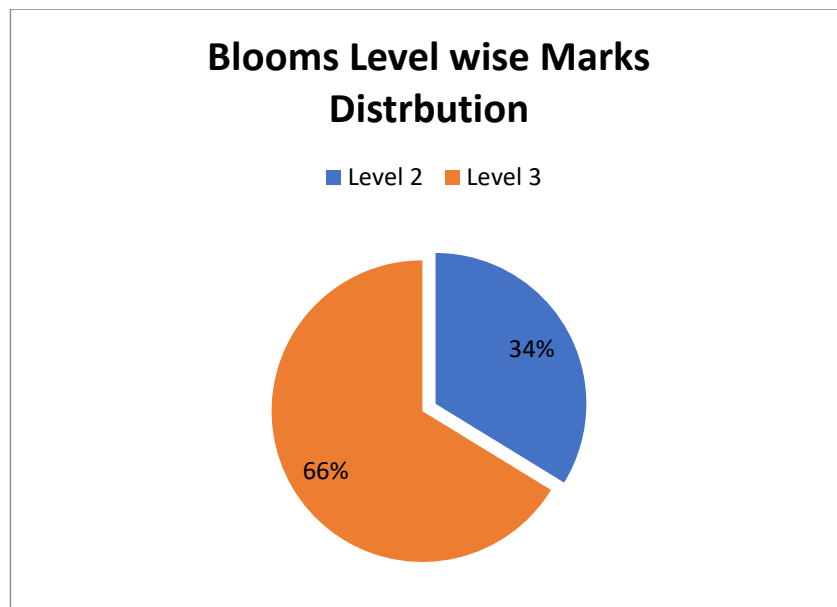

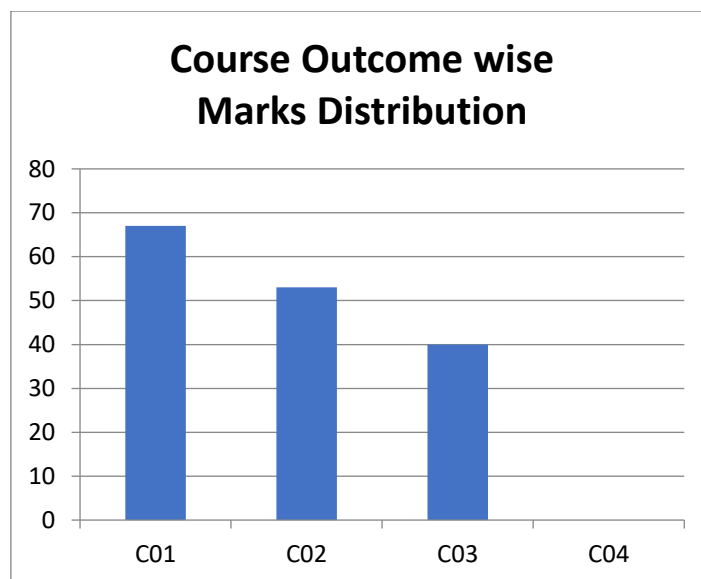

**BL – Bloom’s Taxonomy Levels (1- Remembering, 2- Understanding, 3 – Applying, 4 – Analysing, 5 – Evaluating, 6 - Creating)**

**CO – Course Outcomes**

**PO – Program Outcomes; PI Code – Performance Indicator Code**

## Course Name: Automotive Electronics

Semester: VI (ECE)

Course Outcomes (CO):

1. Discuss the overview of automotive components, subsystems, design cycles, communication protocols and safety systems employed in today's automotive industry.
2. Determine the role of electronics for the areas like In-vehicle architectures, networking, engine management systems, vehicle safety systems & infotainment systems.
3. Select, classify and interface sensors to automotive systems.
4. Establish the need of vehicle safety standards and diagnostics systems in the automotive industry and implications on OEMs, Suppliers and Customers.
5. Design and implement an automotive sub system to realize Electronic Control Unit.

**Model Question Paper**  
**Total Duration (H: M):3:00**  
**Course: Automotive Electronics**  
**Maximum Marks: 100**

Q.No	Questions	Marks	CO	BL	PI
<b>UNIT I</b>					
1a	The vehicle is to be started on a cold winter morning, and then has to navigate hilly terrains. How does the engine cope-up with the different requirements as the vehicle goes from start to cruising? Suggest a design strategy using different control modes with appropriate details.	8	2	3	2.1.2
1b	What is Stoichiometric ratio? i) Calculate Lambda if air fuel ratio is 13.2. ii) Determine the fuel injector pulse duration (base pulse width $T_w$ ) and fuel quantity for the eight cylinder fully warmed up and very cold engine running at 4000 rpm, having a fuel flow rate of 0.0022Kg/sec and mass air flow rate of 0.0035Kg/sec.	6	2	3	1.4.1
1c	For the development of an Engine ECU, apply MBD approach adhering to automotive V design model.	6	1	3	1.4.1
2a	With MAF sensor malfunctioning as detected by the engine control system diagnostic function, how engine control system can work effectively as possible with other existing sensor information for calculating the mass air flow rate.	8	2	3	1.4.1
2b	Assume a vehicle is running at a fixed rpm of 8000 and further the driver demands for increase in speed. How the engine ECU handles driver's request using ignition timing? Suggest a suitable Instrumentation system with related electronics for closed loop control of ignition timing.	6	2	3	2.2.3
2c	Vehicle is moving with a high speed; suddenly the driver applies the brakes, what is the physical consequence of this condition on wet and dry surface? Provide a suitable control system/electronic solution to avoid the damage.	6	1	3	2.2.3
3a	What do you mean by Engine Mapping? For the engine operating in closed loop mode how the variations in, i) Exhaust gas recirculation ii) Air fuel ratio and iii) Ignition timing affect its performance. Show with the necessary plots.	8	2	2	1.4.1

Q.No	Questions	Marks	CO	BL	PI
3b	Elaborate on different segments of automotive industry and also discuss about automotive supply and value chain.	6	1	2	1.4.1
3c	Vehicle is moving on an icy surface with the engine rpm of 4000, but the vehicle is unable to move forward, what is the physical consequence of this condition? Provide a control system solution to overcome this problem.	6	1	2	2.2.3
<b>UNIT II</b>					
4a	Describe the control system which provides a solution for wheel spinning, and discuss the related control functions. Brief on operating sequence of drivers air bag.	8	3	2	1.4.1
4b	Compare event driven and time triggered communication strategies. Calculate nominal and maximum $T_{Header}$ , $T_{Response}$ and $T_{Frame}$ , if LIN is operating at 10Kbps baud rate and reserved time is set to 30% for transmitting two bytes of data.	6	2	3	2.1.2
4c	What is ride and handling of an automobile? How electronic suspension system manages the compromise between ride comfort and handling.	6	3	2	1.4.1
5a	Discuss the physical mechanism of wheel lock and vehicle skid that can occur during braking; How the ABS configuration provides a solution for this. If the vehicle longitudinal acceleration is zero, i) Calculate the wheel slip if vehicle speed is matching with wheel speed? ii) Calculate wheel slip for Fl(Front left) and Fr(Front right), when vehicle speed is 70kph and WssFl(Wheel speed front left) and WssFr(Wheel speed front right) are reading 67kph and 69kph respectively iii) Calculate wheel slip when panic braking is done at 150kph and ABS is shut down due to pump failure?	8	3	3	1.4.1
5b	How to improve the efficiency/performance/reliability of engine control unit by adding any extra sensors for the existing system? Mention the significance of sensors & related variables to be measured for engine control system.	6	3	3	2.2.3
5c	Assume that the driver has activated the cruise control switch set for the desired speed of (say, 60 mph). For the following conditions determine the action of throttle, controlled by the suitable control algorithm ; i) If the car is travelling on a level road ii) If the car were then to enter a long hill with a steady positive slope (i.e., a hill going up). Optimize the system for following performance parameters, 1. Quick response 2. Relative stability 3. Small steady-state error 4. Optimization of the control effort required	6	3	3	2.1.2
6a	Answer the following with respect to CAN communication i) The CAN node receives the message as 1011110, state whether the received information is error free or not. Assume CRC with a generator polynomial as 1011. ii) How small nodes can be kept from overloading with received messages iii) Message prioritization in case of CAN protocol. iv) Draw the message sequence seen by the CAN bus for the given scenario.	8	2	2	1.4.1

Q.No	Questions	Marks	CO	BL	PI
6b	Explain the construction and working principle of magnetic reluctance angular position sensor. What is the drawback of this sensor and how it is overcome? Discuss the operation of fuel injector.	6	3	2	1.4.1
6c	The fast moving car is turning at the corner, if the vehicle is turning less/more than the driver's intention suggest a suitable control system along with the break circuit configuration to overcome this condition.	6	3	3	2.1.2
<b>UNIT III</b>					
7a	For an electric vehicle propulsion system the hazardous event is described as "Un intended vehicle acceleration during a low speed maneuver amongst pedestrians". Perform suitable hazard analysis and risk assessment for this case.	10	3	3	2.1.2
7b	An engine going through cold cranking the air/fuel ratio is not able to be controlled. Analyze the possible faults.	10	3	2	1.4.1
8a	The CAN node has to transmit the speed sensor information from engine ECU to ESP ECU. The size of the information of 5 bits, show how this message is transmitted, and discusses how the CAN receiver node determines whether the message is error free or not.	10	4	3	1.4.1
8b	A 2015 Audi A8 was having a problem with rough running which in turn was causing the engine management light to illuminate. Analyze the possible faults	10	4	3	2.1.2

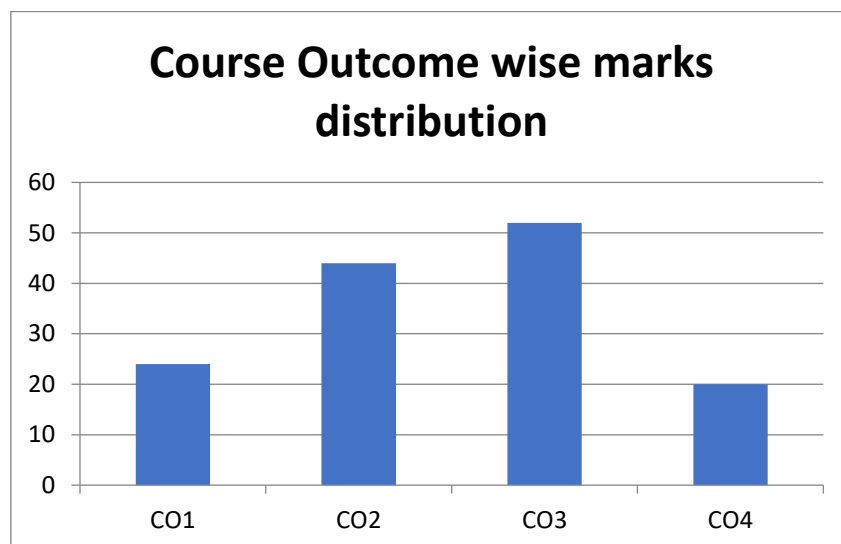
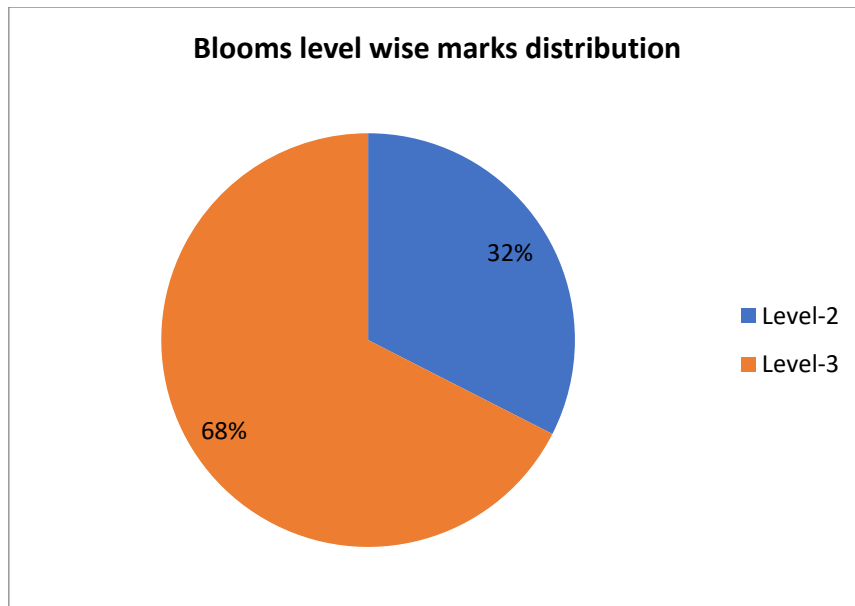

**BL – Bloom’s Taxonomy Levels (1- Remembering, 2- Understanding, 3 – Applying, 4 – Analysing, 5 – Evaluating, 6 - Creating)**

**CO – Course Outcomes**

**PO – Program Outcomes; PI Code – Performance Indicator Code**

## Course Name: CMOS VLSI Circuits

Semester: V (ECE)

Course Outcomes (CO):

6. Illustrate the CMOS VLSI design flow and Outline the CMOS IC fabrication process
7. Model the DC Characteristics and delays of CMOS logic circuits.
8. Design complex CMOS logic circuits using stick diagrams & interpret layout design rules.
9. Design combinational and sequential CMOS logic networks.
10. Analyze and interpret the static and transient performance of logic gates and verify layouts using Cadence tool.
11. Design and analyze combinational and sequential logic circuits using Cadence tool.

**Model Question Paper**  
**Total Duration (H:M): 3:00**  
**Course: CMOS VLSI Circuits**  
**Maximum Marks :100**

Q.No	Questions	Marks	CO	BL	PI
<b>UNIT I</b>					
1a	Analyze the impact of Semi-custom and Full-custom VLSI design styles based on design cycle time and the achievable circuit performance.	6	1	2	1.4.2
1b	What are the limitations of planar VLSI technology, and discuss the advantages and challenges in 3D devices like FinFET devices.	6	1	2	1.2.1
1c	In VLSI fabrication, oxides in varying thickness and compositions are used for different processes. Discuss each of them with relevant examples.	8	1	2	1.2.3
2a	Discuss the capacitance modeling of an nMOS device during cutoff, linear and saturation.	6	2	2	1.4.1
2b	Design an AOI221 gate using fully CMOS logic, so as to achieve same transient performance as that of a reference CMOS Inverter.	6	2	3	14.2.2
2c	<p>Solve the node voltages in the arrangements given below if <math>V_m = 0.6V</math> and <math>V_{tp} = -0.6V</math>. What may happen to the output voltage, if the back-gate effect is also considered?</p>	8	2	3	1.4.1
3a	An inverter needs to be fabricated using planar CMOS technology in a twin-tub process. Illustrate the fabrication steps with cross-sectional views and appropriate masks used at each stage.	10	1	3	1.2.1

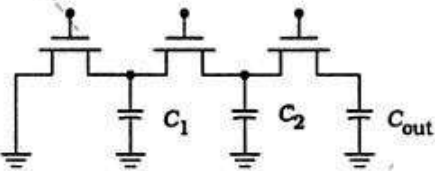
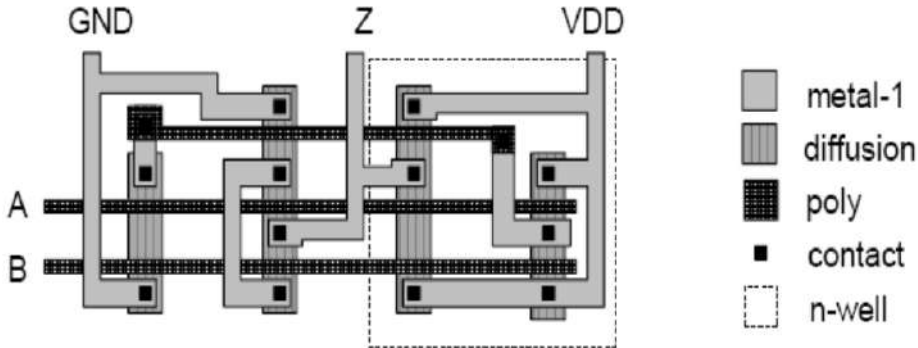
Q.No	Questions	Marks	CO	BL	PI
3b	<p>A circuit designer has a choice to implement combinational logic using NAND or a NOR network. Justify the selection if performance is the criteria, and analyze the speed of a 1 to 0 transition as shown below.</p>  <p>The output cap has a value of <math>C_{out}=130\text{fF}</math>, while the internal values are <math>C_1=C_2=36\text{fF}</math>. The transistors are identical with <math>\beta_n=2.0\text{mA/V}^2</math> in a process where <math>V_{DD}=3.3\text{V}</math> &amp; <math>V_{Th}=0.7\text{V}</math>.</p> <ol style="list-style-type: none"> <li>Find the discharge time constant for <math>C_{out}=130\text{fF}</math> using the ladder RC network.</li> <li>Find the time constant if we ignore <math>C_1</math> &amp; <math>C_2</math>.</li> <li>What is the percentage error introduced if we do not include the internal capacitors?</li> </ol>	10	2	3	2.1.2
<b>UNIT II</b>					
4a	Discuss the phenomenon of latch-up and illustrate ways of dealing with it in CMOS VLSI design.	6	3	2	1.4.2
4b	What is the need to study $\lambda$ -based design rules? How are they different from micron rules? Illustrate $\lambda$ -based design rules with an example layout.	6	3	3	14.2.2
4c	<p>Identify the circuit from the layout given below. Is it a valid layout? If yes then what is the type of logic style it represents?</p> 	8	3	3	2.1.2
5a	Discuss the charge sharing issue in Dynamic CMOS logic. What will happen if we directly cascade two stages of this gate? Propose a remedy for the cascading problem.	6	4	3	14.2.2
5b	In the figure, find the output in terms of inputs A, B and C when the clock CK is high. Also implement the clocked CMOS equivalent of the same.	6	4	3	1.4.2

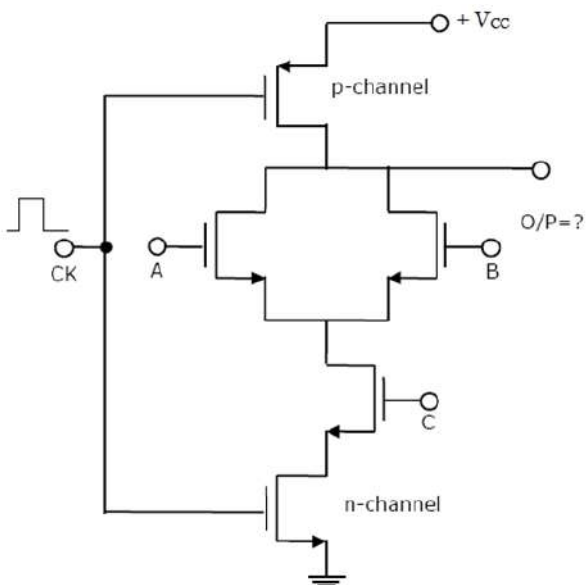
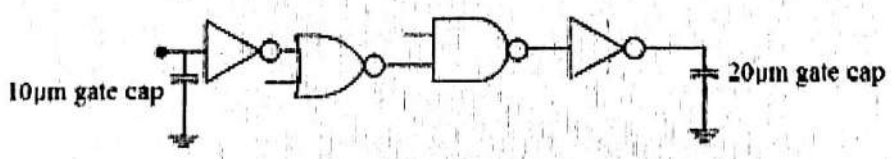
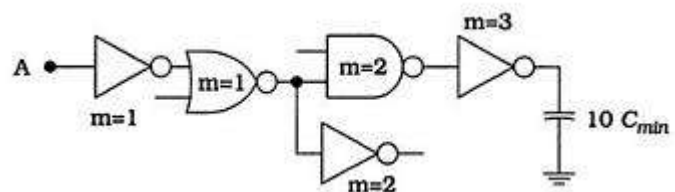

Q.No	Questions	Marks	CO	BL	PI
					
5c	<p>Consider the logic cascade shown in figure below .Use logical effort to find the relative size of each stage needed to minimize delay through the chain. Assume symmetric gates with <math>r = 2.5</math>.</p> 	8	4	3	1.4.2
6a	<p>For the given logical expression for <math>Z = \overline{A(D + E)} + \overline{BC}</math> design a suitable logic circuit using CMOS with stick-diagram layout, and optimize the ordering of poly gates in the layout by using appropriate method.</p>	10	3	3	14.2.2
6b	<p>Consider the logic chain of a co-processor shown below. The input at A is switched from a 1 to 0. Find an expression for the delay time through the chain using an appropriate procedure.</p> 	10	4	3	2.1.2
<b>UNIT III</b>					
7a	<p>Illustrate the flip-flop min-delay constraint with appropriate waveforms and equations.</p>	10	4	3	1.4.2
7b	<p>Explain the working of a standard CMOS flip-flop using TGs.</p>	10	4	2	1.4.2
8a	<p>A simple latch can be implemented using one MOS device. Discuss the variations and design improvements that can be made based on logic requirements.</p>	10	4	3	1.4.2

Q.No	Questions	Marks	CO	BL	PI
8b	Write a short note on Global clock-generation and distribution	10	4	2	1.4.2

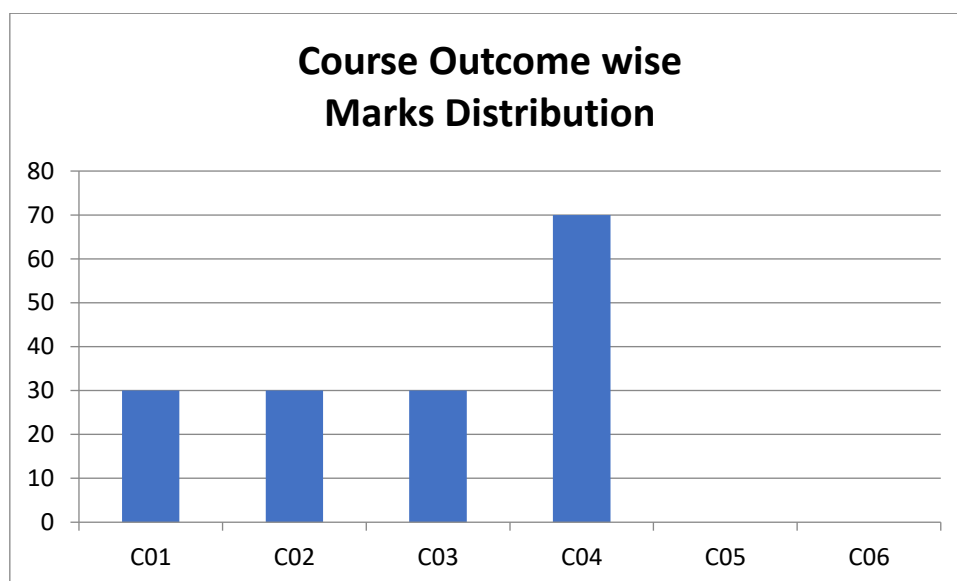
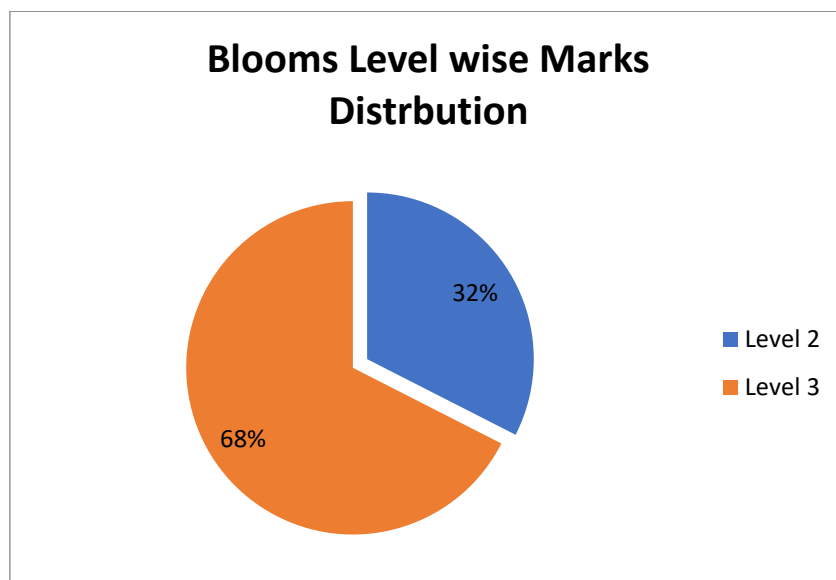

**BL – Bloom’s Taxonomy Levels (1- Remembering, 2- Understanding, 3 – Applying, 4 – Analysing, 5 – Evaluating, 6 - Creating)**

**CO – Course Outcomes**

**PO – Program Outcomes; PI Code – Performance Indicator Code**

## Course Name: Digital Circuits

Semester: III (ECE)

Course Outcomes (CO):

1. Evaluate the performance metrics of digital circuits.
2. Design a combinational circuit using Medium Scale Integration (MSI) devices by applying suitable reduction techniques.
3. Design a sequential circuit using Flip Flops.
4. Illustrate the role of different types of memories in computer system.
5. Design & implement combinational/sequential logic system for a given application to meet the functional requirements.

**Model Question Paper**  
**Total Duration (H: M): 3:00**  
**Course: Digital Circuits**  
**Maximum Marks: 100**

Q.No	Questions	Marks	CO	BL	PI
<b>UNIT I</b>					
1a	Explain the working of ECL OR gate with the help of neat circuit diagram.	5	1	2	1.4.2
1b	Rewrite the following Boolean expression in the minterm and maxterm canonical forms. $P=F(x,y,z) = x'(y'+z)+z'$	5	2	2	1.4.1
1c	Design a digital circuit using minterm and maxterm generators to realize the following functionality. $F(A,B,C,D) = \sum m(0,1,3,4, 9,10,11,15)$ . Use only 2- input gates.	10	2	3	2.2.3
2a	On a certain weekend Ramu, Raheem and Johnny planned to have lunch in a restaurant and/or watch a movie. i) When all friends agree, they will have lunch after watching a movie. ii) No question of going out when none of them agree. iii) If Ramu agrees, then irrespective of others opinion, they only have lunch together. iv) If Ramu disagrees, they will only watch a movie. Design a suitable digital system by using a positive logic, for the above conditions with a non programmable technique in SOP and POS formats.	10	2	3	2.2.3
2b	Realize the following Boolean function with multiplexer $F(A,B,C,D) = \sum m(0,1,3,4,8,9,15)$ i) Using 16:1 MUX ii) Using 8:1 MUX with A,B,C select lines iii) Using 4:1 MUX with A,B select lines	10	2	3	1.4.1
3a	Identify a technique that cannot be programmed and that is used for less number of variables, to provide minimal sums and minimal products for the following Boolean function. $f(w,x,y,z) = \sum m(1,5,8,14) + X(4,6,9,11,15)$	10	2	3	2.2.3

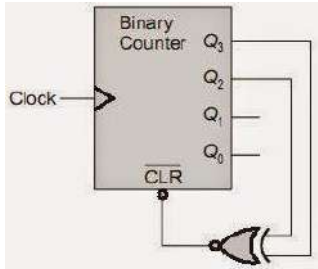
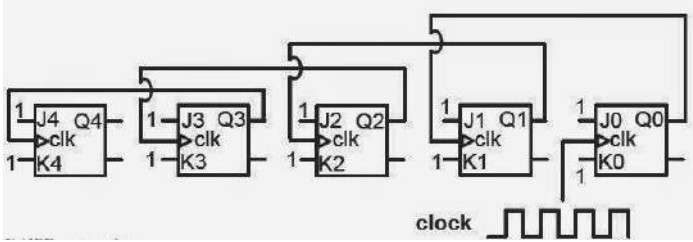
Q.No	Questions	Marks	CO	BL	PI
3b	Design a digital system to add two Binary Coded Decimal numbers using binary adder.	10	2	3	1.4.1
<b>UNIT II</b>					
4a	Explain the operation of a SR latch.	7	3	2	1.4.2
4b	Design a 4-bit Johnson counter using the principle of Universal Shift Register (USR)	7	3	3	1.4.1
4c	<p>The figure shows a binary up counter with synchronous clear input. With the decoding logic shown, the counter works as a Mod-n counter. Find the value of n.</p> 	6	3	3	1.4.2
5a	What is race around condition? Explain the remedy for the same problem in case of JK F/F.	7	3	2	1.4.2
5b	<p>Design a digital system using minimum number of data flip flops to monitor the number of buses available in the bus depot on daily basis for the following conditions, over a week.</p> <ul style="list-style-type: none"> <li>On Sunday the occupancy of bus depot is 15 buses.</li> <li>On Monday 2 buses were sent for service.</li> <li>On Tuesday 3 buses went for college trip.</li> <li>On Wednesday 1 bus returned from service.</li> <li>Next day 5 more buses left for marriage party.</li> <li>On Friday buses returned from college trip.</li> <li>On Saturday 2 buses were sent for service.</li> </ul>	7	3	3	2.2.2
5c	<p>Five JK flip-flops are cascaded to form the circuit shown in figure. Clock pulses at a frequency of 1MHz are applied as shown. Compute the frequency (in KHz) of the wave form at Q3.</p> 	6	3	3	1.4.2
6a	Analyze a negative edge triggered D Flip-Flop with the help of timing diagram.	7	3	3	1.4.2

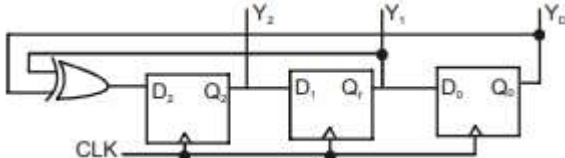
Q.No	Questions	Marks	CO	BL	PI																																																	
6b	Design a digital system using suitable logic to count from $(0010)_2$ till it reaches $(1101)_2$ continuously. The external clock is given to the first Flip-Flop and triggers it during rising edge of the pulse. The successive Flip-Flops are to be triggered by its predecessors.	7	3	3	2.2.2																																																	
6c	A three bit pseudo random generator is as shown. Initially the value of output $Y=Y_2Y_1Y_0$ is set to 111. Evaluate the value of output Y after three clock cycles. 	6	3	3	1.4.2																																																	
<b>UNIT III</b>																																																						
7a	Draw Mealy and Moore synchronous machine models and label the excitation variables, state variables, input and output variables.	10	3	2	1.4.2																																																	
7b	Design a digital controller for the state table given below using a sequential component with single input. <table border="1" style="margin-left: auto; margin-right: auto;"> <thead> <tr> <th colspan="2">Present state</th> <th rowspan="2">Input X</th> <th colspan="2">Next state</th> </tr> <tr> <th>A</th> <th>B</th> <th>A<sup>+</sup></th> <th>B<sup>+</sup></th> </tr> </thead> <tbody> <tr><td>0</td><td>0</td><td>0</td><td>0</td><td>0</td></tr> <tr><td>0</td><td>1</td><td>0</td><td>0</td><td>1</td></tr> <tr><td>0</td><td>0</td><td>1</td><td>1</td><td>0</td></tr> <tr><td>0</td><td>1</td><td>1</td><td>0</td><td>1</td></tr> <tr><td>1</td><td>0</td><td>0</td><td>1</td><td>0</td></tr> <tr><td>1</td><td>1</td><td>0</td><td>1</td><td>1</td></tr> <tr><td>1</td><td>0</td><td>1</td><td>1</td><td>0</td></tr> <tr><td>1</td><td>1</td><td>1</td><td>0</td><td>1</td></tr> </tbody> </table>	Present state		Input X	Next state		A	B	A <sup>+</sup>	B <sup>+</sup>	0	0	0	0	0	0	1	0	0	1	0	0	1	1	0	0	1	1	0	1	1	0	0	1	0	1	1	0	1	1	1	0	1	1	0	1	1	1	0	1	10	3	3	2.2.3
Present state		Input X	Next state																																																			
A	B		A <sup>+</sup>	B <sup>+</sup>																																																		
0	0	0	0	0																																																		
0	1	0	0	1																																																		
0	0	1	1	0																																																		
0	1	1	0	1																																																		
1	0	0	1	0																																																		
1	1	0	1	1																																																		
1	0	1	1	0																																																		
1	1	1	0	1																																																		
8a	Differentiate between SRAM, DRAM, NVRAM.	10	4	2	1.4.1																																																	
8b	Explain the read and write operations of SRAM.	10	4	2	1.4.1																																																	

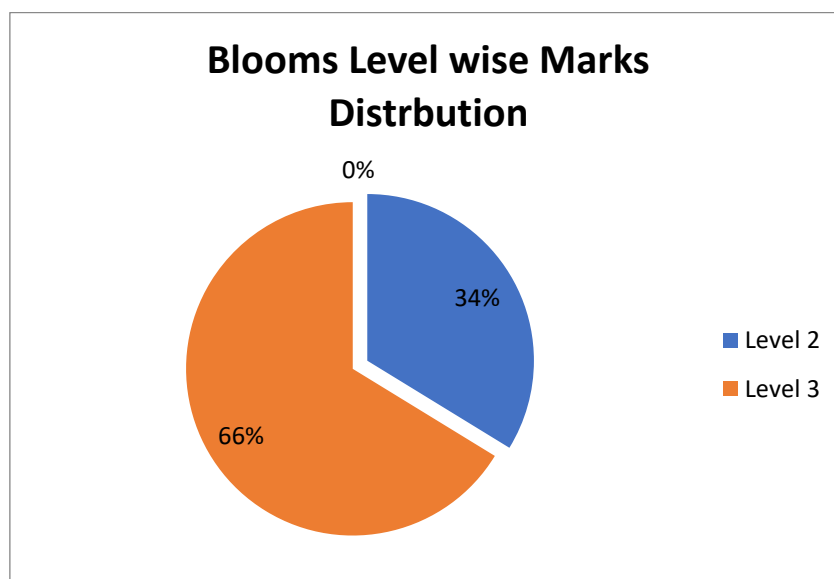

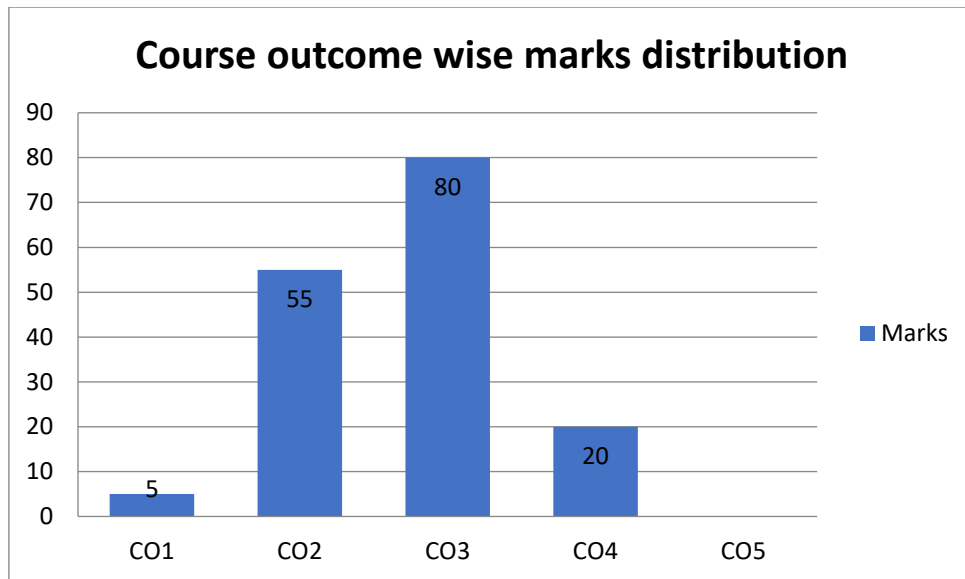

**BL – Bloom’s Taxonomy Levels (1- Remembering, 2- Understanding, 3 – Applying, 4 – Analysing, 5 – Evaluating, 6 - Creating)**

**CO – Course Outcomes**

**PO – Program Outcomes; PI Code – Performance Indicator Code**

## Course Name: Linear Integrated Circuits

Semester: IV (ECE)

Course Outcomes (CO):

1. Describe the operation of current mirror, differential Amplifier using MOSFET and analyze the respective performance parameters.
2. Design and analyze the operations of linear applications using Op-amp for the given specifications.
3. Design and analyze the operations of non-linear applications using Op-amp for the given specification.
4. Realize the functional block for a given application and specifications using op-amp and linear ICs and verify its functionality using simulator tool.

**Model Question Paper**  
**Total Duration (H: M):3:00**  
**Course: Linear Integrated Circuits**  
**Maximum Marks: 100**

Q.No	Questions	Marks	CO	BL	PI
<b>UNIT I</b>					
1a	Derive the expression for output impedance of Wilson current mirror with relevant circuit diagram and equivalent circuits.	6	1	3	1.4.2
1b	For the non inverting amplifier $R_1=470\Omega$ and $R_F=4.7K \Omega$ , $A=200000$ , $R_i=2M \Omega$ , $R_o=75 \Omega$ , $F_o=5Hz$ , supply voltage is $\pm 15V$ and output voltage swing is $\pm 13V$ . Calculate the values of $A_F$ , $R_{if}$ , $R_{of}$ , $F_f$ and $V_{OOT}$	6	1	2	1.4.2
1c	Consider the circuit shown below, assuming $(W/L)_{1-3}=40/0.5$ , $I_{ref}=0.3mA$ a. Determine $V_b$ such that $V_x=V_y$ b. If $V_b$ deviates from the value calculated in part (a) by 100mV, what is the mismatch between $I_{out}$ and $I_{ref}$ ?	8	1	3	2.1.2
2a	Derive an output voltage expression for 5-pack differential amplifier with neat circuit diagram with relevant Explanation.	6	1	3	1.4.2
2b	Discuss the effect of negative feedback on non-idealities of the Op-amp, with neat diagram and relevant equations.	6	1	2	1.4.1
2c	Identify the circuit shown below where all transistors have $V_t=0,6V$ , $\mu_n C_{ox}=160$ $W_1=W_4=4\mu m$ , and $W_2=W_3=40\mu m$ . $L=1\mu m$ and $I_{REF}$ is $20\mu A$ . Determine the	8	1	3	2.1.2

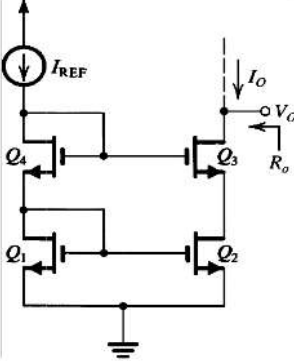
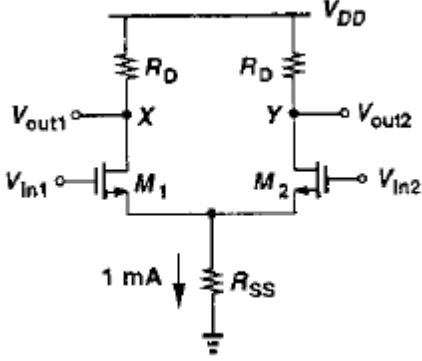
Q.No	Questions	Marks	CO	BL	PI
	<p>output current and the voltages at the gates of <math>Q_2</math> and <math>Q_3</math>. What is the lowest voltage at the output for which current source operation is possible? What are the values of <math>g_m</math> and <math>r_o</math> of <math>Q_2</math> and <math>Q_3</math>? What is the output resistance of the circuit?</p> 				
3a	<p>Identify the amplifier configuration given below, with <math>(W/L)_{1,2}=25/0.5</math>, <math>\mu_n C_{ox}=50\mu A/V^2</math>, <math>V_{TH}=0.6V</math>, <math>\lambda=\gamma=0</math> and <math>V_{DD}=3V</math></p> <p>a. What is the required input CM for which <math>R_{SS}</math> sustains 0.5V?</p> <p>b. Calculate <math>R_D</math> for a differential gain of 5</p> 	6	1	3	2.1.2
3b	<p>List the ideal characteristics of an OPAMP. Give its symbolical representation and explain the functions of each terminal. Tabulate the ideal op-amp terminal characteristics.</p>	6	1	2	1.4.2
3c	<p>For the differential amplifier with the current mirror as a load ,determine the <math>(W/L)</math> and drain current of all MOSFET's for the following specifications: <math>V_{dd}=-V_{ss}=2.5V</math>, <math>SR \geq 10V/\mu s</math> (<math>C_{load}=5pf</math>), <math>f_{-3db} \geq 100kHz</math> (<math>CL=5pF</math>), a small signal voltage gain of 100, <math>-1.5 \leq ICMR \leq 2V</math> and <math>P_{diss} \leq 1mW</math>. Model parameters: <math>K_N' = 110\mu A/V^2</math>, <math>K_P' = 50\mu A/V^2</math>, <math>V_{TP} = -0.7V</math>, <math>V_{TN} = 0.7V</math>, <math>\lambda_N = 0.04V^{-1}</math>, <math>\lambda_P = 0.05V^{-1}</math>.</p>	8	1	3	1.4.1
<b>UNIT II</b>					
4a	<p>Derive the expression for the output current <math>I_o</math> in terms of input voltage <math>V_{in}</math> for a grounded load using Op-amp.</p>	7	2	3	1.4.2
4b	<p>Describe the inverting differentiator and obtain the expression for the output voltage with neat circuit diagram and waveforms</p>	7	2	3	1.4.2
4c	<p>Identify the following circuit operation. Find</p>	6	2	3	1.4.2

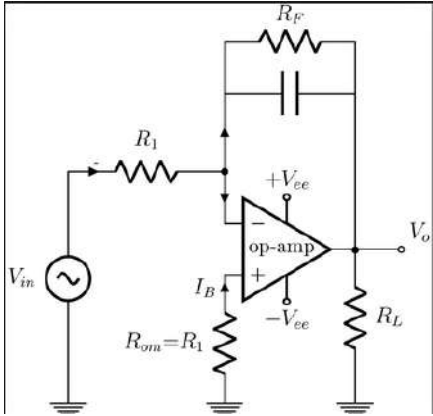
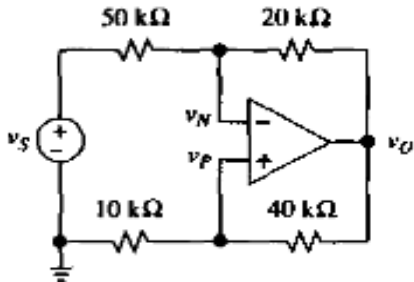
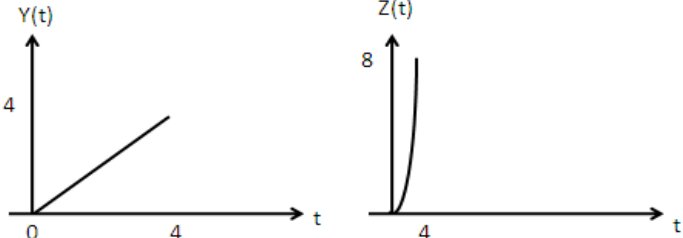

Q.No	Questions	Marks	CO	BL	PI
	<p>1. Lower frequency limit of the operation and                      2. Response for the step, square and sine inputs for <math>R_1=10K\Omega</math>, <math>R_f=100 K\Omega</math> and <math>C_f=1nF</math></p> 				
5a	<p>Derive the expression for summing and averaging amplifier output for</p> <ul style="list-style-type: none"> <li>• Non-inverting amplifier</li> <li>• Differential amplifier</li> </ul> <p>Using Op-amp with neat circuit diagram.</p>	7	2	3	1.4.2
5b	<p>Two different pre-amp microphones are used in a recording studio, one for vocals and other for the musical instrument with output voltage in the range of 0-2V and 0-0.5V respectively. Design a suitable circuit using Op-Amp to combine signals from both the microphones in such a way that the signal corresponding to the musical instrument should be twice amplified as that of vocal signal.</p>	7	2	3	2.1.2
5c	<p>i. Find <math>V_N, V_P</math> and <math>V_o</math> in the circuit if <math>V_S=9V</math>                      ii. Find the resistance <math>R</math> that, if connected between the inverting input pin of the op-amp and ground which causes <math>V_o</math> to double.</p> 	6	2	3	1.4.2
6a	<p>Obtain the output expression using a suitable circuit to get the following waveform <math>Z(t)</math> at the output side. Explain with the help of frequency response.</p> 	7	1	2	1.4.2

Q.No	Questions	Marks	CO	BL	PI
6b	It is required to measure the weight of the vehicle using weigh bridge system, arrive at a suitable signal conditioning circuit for measuring the weight in terms of voltage. Using circuit analysis techniques arrive at an expression for the output voltage in terms of input weight.	7	1	3	2.1.2
6c	Obtain a suitable circuit for the following frequency response with $A_F=10$ , $f_H$ and also derive the expression for the gain $A_F$ and cut off frequency $f_H$	6	2	3	2.1.2

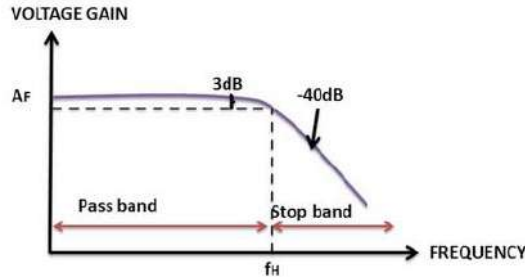

**UNIT III**

7a.	Design a circuit using Op-Amp to obtain the following transfer characteristics. Explain the operation using waveforms and obtain the expressions. $V_{LTP}=-2$ ; $V_{UTP}=3$ ; $V_{SAT}=15$ ; $-V_{SAT}=-15$ .	10	3	3	2.1.2
-----	--	----	---	---	-------

7b.	Draw the circuit configuration to generate triangular wave, describe the circuit operation using waveforms.	10	3	2	1.4.2
8a.	Implement a monostable multivibrator using the timer circuit shown in below figure. Also determine an expression for ON time 'T' of the output pulse.	10	3	3	1.4.2

8b.	Explain the precision peak detector and precision clamping circuit with neat diagrams.	10	3	2	1.4.2
-----	--	----	---	---	-------

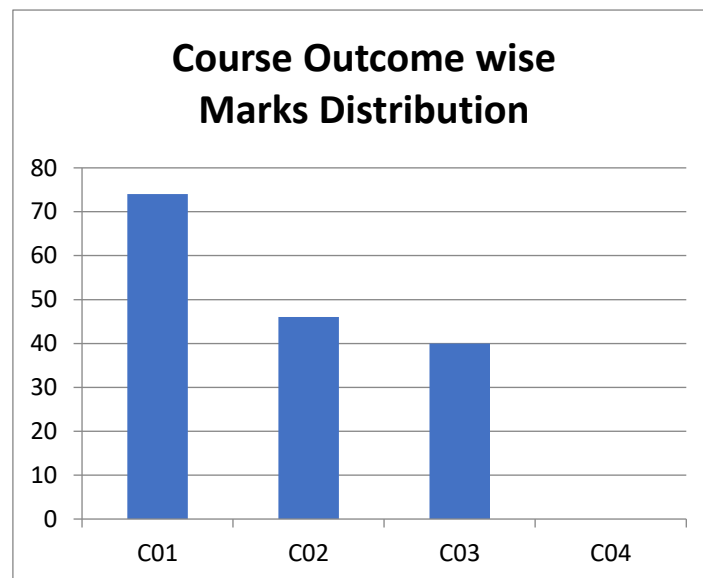
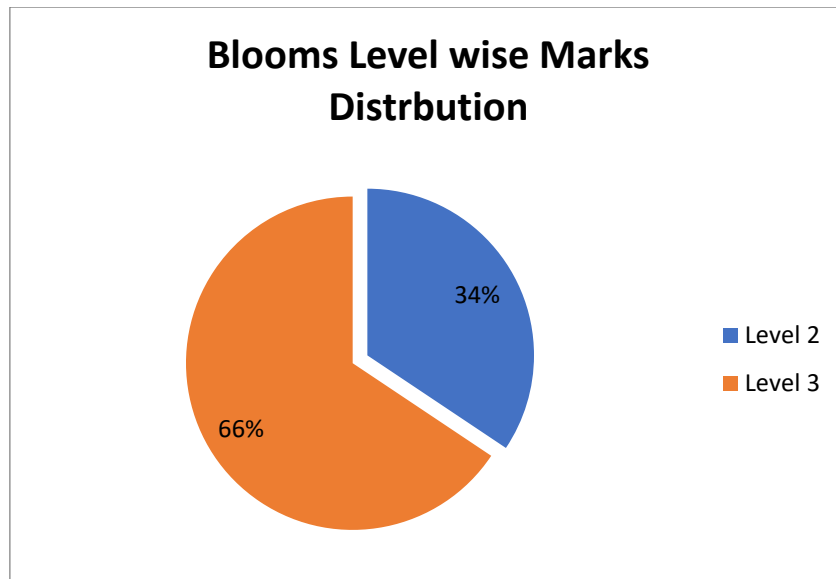

**BL – Bloom’s Taxonomy Levels (1- Remembering, 2- Understanding, 3 – Applying, 4 – Analysing, 5 – Evaluating, 6 - Creating)**

**CO – Course Outcomes**

**PO – Program Outcomes; PI Code – Performance Indicator Code**

## Course Name: Operating System and Embedded Systems

Semester: V (ECE)

Course Outcomes (CO):

12. Discuss the core structure and functionality of operating system and Real-time Operating system.
13. Study and analyze various algorithms related to process management and resource management.
14. Discuss the various Kernel objects used to achieve task synchronization and communication.
15. Discuss the concepts of embedded system, their classification and categorize the components of typical embedded systems.
16. Develop an embedded application for given specification with hardware and software requirements

**Model Question Paper**  
**Total Duration (H:M): 3:00**  
**Course: Operating System and Embedded Systems**  
**Maximum Marks :100**

Q.No	Questions	Marks	CO	BL	PI																												
<b>UNIT I</b>																																	
1a	Calculate the average wait time & TAT for following processes using <ul style="list-style-type: none"> <li>• SJF (pre-emptive &amp; non-pre-emptive),</li> <li>• Priority scheduling</li> <li>• RR</li> </ul> Compare their performance. <table border="1" style="margin-left: auto; margin-right: auto;"> <thead> <tr> <th>Process</th> <th>AT</th> <th>BT</th> <th>Priority</th> </tr> </thead> <tbody> <tr> <td>P1</td> <td>0</td> <td>4</td> <td>0</td> </tr> <tr> <td>P2</td> <td>1</td> <td>5</td> <td>1</td> </tr> <tr> <td>P3</td> <td>3</td> <td>2</td> <td>2</td> </tr> <tr> <td>P4</td> <td>4</td> <td>1</td> <td>3</td> </tr> <tr> <td>P5</td> <td>2</td> <td>6</td> <td>4</td> </tr> <tr> <td>P6</td> <td>6</td> <td>6</td> <td>5</td> </tr> </tbody> </table>	Process	AT	BT	Priority	P1	0	4	0	P2	1	5	1	P3	3	2	2	P4	4	1	3	P5	2	6	4	P6	6	6	5	8	2	3	1.4.5
Process	AT	BT	Priority																														
P1	0	4	0																														
P2	1	5	1																														
P3	3	2	2																														
P4	4	1	3																														
P5	2	6	4																														
P6	6	6	5																														
1b	i. Apply suitable code optimization techniques for the following C statements. ii. Determine the longest path through each code fragment, assuming that all statements can be executed in equal time and that all branch directions are equally probable. <table border="1" style="margin-left: auto; margin-right: auto;"> <tbody> <tr> <td style="width: 50%; padding: 5px;">               a.     if (i &lt; 10) { x = a + b; }                      else { x = c - d; y = e + f; }             </td> <td style="width: 50%; padding: 5px;">               b.     for (i = 0; i &lt; 32; i++)                      if (a[i] &lt; 20)                          x[i] = a[i] * c[i];             </td> </tr> <tr> <td style="padding: 5px;">               c.     if (a &lt; 30) {                      if (b &lt; 40)                          w = r + s; else {                          w = r - s;                          x = s + t;                          }                      }                      }             </td> <td style="padding: 5px;">               if (c &gt; 50) {                      w = r + t;                      x = r - s;                      y = s + u;                      }                      }             </td> </tr> </tbody> </table>	a.     if (i < 10) { x = a + b; } else { x = c - d; y = e + f; }	b.     for (i = 0; i < 32; i++) if (a[i] < 20) x[i] = a[i] * c[i];	c.     if (a < 30) { if (b < 40) w = r + s; else { w = r - s; x = s + t; } } }	if (c > 50) { w = r + t; x = r - s; y = s + u; } }	6	3	3	2.2.3																								
a.     if (i < 10) { x = a + b; } else { x = c - d; y = e + f; }	b.     for (i = 0; i < 32; i++) if (a[i] < 20) x[i] = a[i] * c[i];																																
c.     if (a < 30) { if (b < 40) w = r + s; else { w = r - s; x = s + t; } } }	if (c > 50) { w = r + t; x = r - s; y = s + u; } }																																

Q.No	Questions	Marks	CO	BL	PI
	<pre> else { } </pre>				
1c	Suppose computer system hardware is to be operated without an OS, discuss the scenario of using this computer for running an application in which password authentication is to be made. Discuss disadvantages of a computer without an OS. Elaborate on the role of OS and its functions.	6	1	2	1.4.3
2a	Under what circumstances is rate-monotonic scheduling inferior to earliest-deadline-first scheduling in meeting the deadlines associated with processes? Consider the following activities of a car control system. 1. C= worst case execution time 2. T= (sampling) period 3. D= deadline Speed measurement: C=4ms, T=20ms, D=20ms ABS control: C=10ms, T=40ms, D=40ms Fuel injection: C=40ms, T=80ms, D=80ms Try any of the two methods to schedule the tasks.	8	2	3	2.2.3
2b	In a multiprogramming and time sharing environment, several users share the system simultaneously. Discuss the security problems that may arise in the situation. Assess the degree of security that can be achieved in both the cases.	6	3	2	1.4.3
2c	It is required to generate a student's register enrolled for engineering course in alphabetical order to distribute student's ID. Develop a code using i. Inline assembly ii. Mixed assembly comment on the performance w.r.t time and memory using appropriate optimization technique	6	1	3	2.2.3
3a	Convert the algorithm given in flowchart into 1) "Normal" assembler, where only branches can be conditional. 2) ARM assembler, where all instructions are conditional. 3) Develop 'C' code with optimization 4) Comment on performance w.r.t 1, 2 and 3	8	3	3	2.2.3
	<pre> graph TD     Start([Start]) --&gt; D1{r0 = r1?}     D1 -- Yes --&gt; Stop([Stop])     D1 -- No --&gt; D2{r0 &gt; r1?}     D2 -- Yes --&gt; P1[r0 = r0 - r1]     D2 -- No --&gt; P2[r1 = r1 - r0]     P1 --&gt; D1     P2 --&gt; D1 </pre>				
3b	Construct a simple "for loop" in C which operates on an array element in each iteration. Then rewrite the code using suitable loop optimization techniques. Comment on the performance.	6	1	3	1.4.3
3c	An Operating system's PID manager is responsible for managing process identifiers. A unique ID is assigned to the process when it is first created. Discuss how this PID is managed using PCB. Elaborate on process and PCB.	6	2	2	1.4.3

Q.No	Questions	Marks	CO	BL	PI
<b>UNIT II</b>					
4a	Write a code for the scenario where an application needs to perform division operation and display the result on a serial port i. Whenever the divisor is found to be zero, message to be displayed is “division error” ii. Whenever the divisor is smaller than zero, message to be displayed is “underflow error”.	8	2	3	2.2.3
4b	An automotive company claims that the active suspension components in its newest vehicles analyze and respond to road conditions for every 2.5 cm at 100 kilometers per hour (1 inch of highway travel at 60 mph). Develop a prototype C code by applying RTOS concepts to realize the above scenario.	6	3	3	1.4.3
4c	Write an application to measure the time taken to execute the “for loop” i) With “loop unrolling” ii) Without “loop unrolling” Both loops are part of two different tasks. Display the time using serial port.	6	1	3	1.4.5
5a	Write an optimized code to create two applications: i. “App1” to convert analog to digital data and store the result in memory pool, ii. “App2” to use this information and display on serial port. Demonstrate optimization with code profiling.	8	2	3	2.2.3
5b	What are the different means of achieving multitasking? Explain with suitable examples.	6	3	2	1.4.3
5c	Develop a prototype C code by applying RTOS concepts to realize the simple vending machine. The vending machine will sell bottles for \$75. Customers can enter either a dollar or quarters. Once sufficient amount of money is entered, the vending machine will dispense a bottle of water. If user enters a dollar it will return one quarter in change. A Money Receiver detects the total money entered. The bottle dispenser system holds the water bottles and releases one bottle when the input signal is asserted. A coin return system holds quarters for change and will release one quarter when input is dollar. The money receiver will reject money if a dollar and quarter are entered simultaneously.	6	1	3	2.2.3
6a	Write a code to create 3 applications, where they share stepper motor: i. “App1” rotates stepper motor in clockwise for 5 rotations ii. “App2” rotates it in anticlockwise for 5 rotations iii. “App3” stops it for one second (use hardware timer)	8	3	3	2.2.3
6b	Consider a machine with 64 MB physical memory and a 32-bit virtual address space. If the page size is 4KB, what is the approximate size of the page table? Explain the steps with neat diagrams.	6	1	2	1.4.3
6c	Two analog sensors are connected to INT0 & INT1 to monitor blood pressure and body temperature respectively. It is required to generate an alarm if any of the readings exceed the set threshold value. Identify the number of tasks, kernel objects and scheduling algorithm required to handle this situation. Develop a code to demonstrate the same.	6	2	3	1.4.5
<b>UNIT III</b>					
7a	Consider a 2M-pixel digital camera with 24 bits per pixel, 8 Mbytes of memory, and a 128-Mbyte flash card. Assuming computation is instantaneous, with a 10-	10	3	3	2.2.3

Q.No	Questions	Marks	CO	BL	PI
	ns word-addressed memory, how many pictures per minute can you take, and after how many pictures does the camera stop writing pictures to the flash? How does this change for a 3M-pixel digital camera with all other parameters remaining the same?				
7b	Why is backward compatibility less important in an embedded device than in a general-purpose device? In what ways it is still important?	10	3	2	1.4.3
8a	Explain the advantages of wireless devices. How do wireless devices network using different protocol?	10	4	2	1.4.3
8b	Develop a C code to program RTC to generate HOURS, MINUTES and SECONDS using I2C protocol.	10	4	3	1.4.5

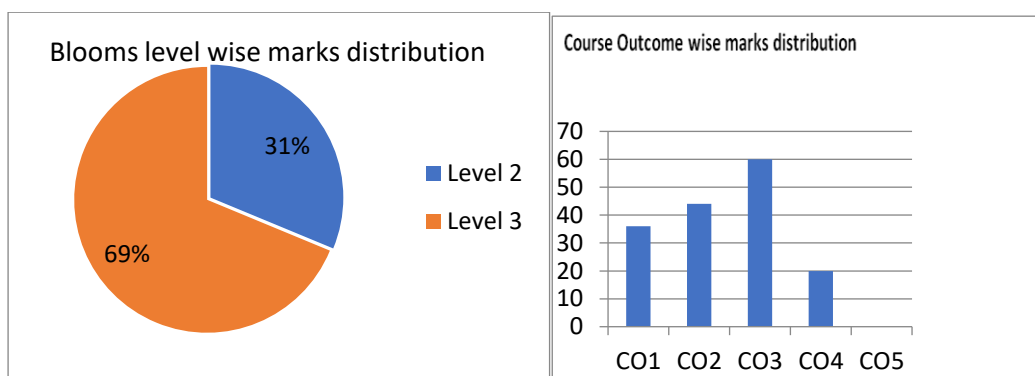

**BL – Bloom’s Taxonomy Levels (1- Remembering, 2- Understanding, 3 – Applying, 4 – Analysing, 5 – Evaluating, 6 - Creating)**

**CO – Course Outcomes**

**PO – Program Outcomes; PI Code – Performance Indicator Code**

## Course Name: Signals and Systems

Semester: III (ECE)

Course Outcomes (CO):

1. Identify different signals and systems and state their properties both in Continuous and discrete domain.
2. Apply the concept of impulse response and perform convolution in both Continuous and discrete domain to analyze the linear time invariant systems.
3. Perform spectral analysis of discrete time periodic and aperiodic signals using Fourier series, Fourier transform and Z transform techniques.
4. Perform the transformations on a given signal and identify appropriate operations.

**Model Question Paper**  
**Total Duration (H: M): 3:00**  
**Course: Signals and Systems**  
**Maximum Marks: 100**

Q.No	Questions	Marks	CO	BL	PI
<b>UNIT I</b>					
1a	Categorize the following signal in terms of energy or power and compute its value. <div style="text-align: center;"> </div>	6	1	2	1.1.3
1b	Obtain the response and sketch the output of the system for the signals $x_1(n) = 0.5[u(n) - u(n-3)]$ and $x_2(n) = u[n] - u[n-2]$ .	8	2	3	2.1.2
1c	Consider the system shown below; determine whether it is (a) memory less (b) Causal (c) linear (d) time-invariant or (e) Stable. <div style="text-align: center;"> </div>	6	1	3	1.1.3
2a	For given signals $x(n)$ and $h(n)$ compute the interaction between signal and the impulse response of a system. $x(n) = \{1, 3, -1, 4\}$ $h(n) = \{4, -1, 2\}$ <div style="text-align: center;"> </div>	6	1	3	2.1.2
2b	A Continuous-time signal $x[t]$ is shown in figure below. Sketch each of the following signals. a) $x[t-4]$ b) $x[3t+7]$ c) $x[-1(t+2)]$ d) $x[-t+2]$	8	1	2	1.1.3

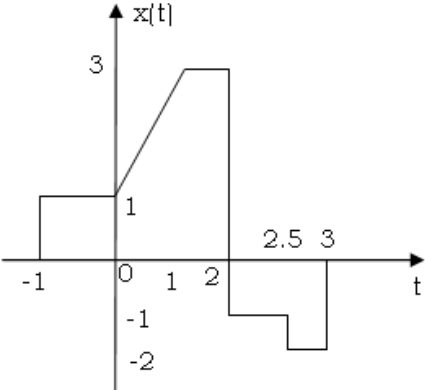
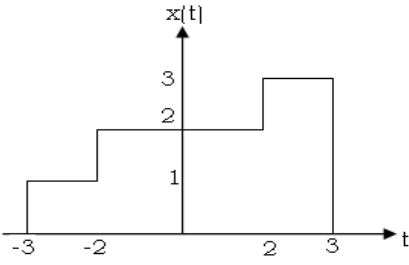
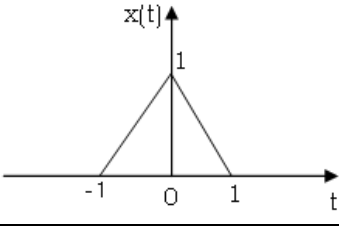

Q.No	Questions	Marks	CO	BL	PI
					
2c	<p>Construct signal <math>x(t)</math> using suitable elementary signals. Express <math>x(t)</math> in terms of the same.</p> 	6	1	3	2.1.2
3a	<p>Determine whether the discrete-time signal <math>x(n) = \sin\left(\frac{1}{3}\pi n\right) \cos\left(\frac{1}{5}\pi n\right)</math> is periodic. If periodic, find the fundamental period.</p>	6	1	2	1.1.3
3b	<p>Consider the signals <math>h(t)=[u(t)-u(t-1)]</math> and <math>x(t)</math> shown below. Obtain the response of the system.</p> 	8	2	3	2.1.4
3c	<p>Sketch the Direct form I implementation for the difference equation,</p> $y(n) - \frac{1}{4}y(n - 1) + \frac{1}{8}y(n - 2) = x(n) + \frac{1}{2}x(n - 2)$ <p>And also propose a solution to implement the difference equation with minimum number of hardware and also sketch the same.</p>	6	2	3	1.1.3
<b>UNIT II</b>					
4a	<p>Prove the following properties of DTFT</p> <p>a) Frequency Differentiation Property</p> <p>b) Time shift property.</p>	6	3	2	1.1.3
4b	<p>Using appropriate transformation compute the frequency response of the following time domain signal shown below. Plot the magnitude and phase spectrum. Also Verify Parseval's identity.</p>	8	4	3	2.1.4

Q.No	Questions	Marks	CO	BL	PI
4c	Obtain the frequency response of the LTI system described the impulse response a) $h(n) = 1/8 (7/8)^n \cdot u(n)$ b) $h(t) = \delta(t) - 2e^{-2t} \cdot u(t)$	6	4	3	1.1.3
5a	Using appropriate transformation compute the frequency response of the following time domain signal: $x(n) = (1/2)^n \cdot \{u(n + 3) - u(n - 2)\}$	6	3	3	2.1.4
5b	Obtain the impulse response of the system having the input $x(n) = (1/2)^n \cdot u(n)$ and output $y(n) = 1/4 (1/2)^n \cdot u(n - 1) + (1/4)^n \cdot u(n)$ .	8	3	3	2.1.2
5c	Prove the following properties of DTFS a) Convolution Property b) Linearity property.	6	3	2	1.1.3
6a	Using appropriate transformation find and sketch the time domain signal corresponding to the following Fourier representation. $X(k) = 2 + 2 \cos\left(\frac{\pi}{4}\right)k + \cos\left(\frac{\pi}{2}\right)k + \frac{1}{2} \cos\left(\frac{3\pi}{4}\right)k$	6	4	3	2.1.2
6b	$x(n) = \{4, -2, 1, 0, -2, -3, 1, 5, -1\}$ Let $\uparrow$ be a sequence with DTFT $X(e^{j\Omega})$ . Evaluate the following functions of $X(e^{j\Omega})$ without computing $X(e^{j\Omega})$ . a) $X(e^{j0})$ b) $X(e^{j\pi})$ c) $\int_{-\pi}^{\pi} X(e^{j\Omega}) d\Omega$ d) $\int_{-\pi}^{\pi}  X(e^{j\Omega}) ^2 d\Omega$ e) $\int_{-\pi}^{\pi} \left  \frac{dX(e^{j\Omega})}{d\Omega} \right ^2 d\Omega$	8	3	3	1.1.3
6c	Obtain the impulse response of the system described by the following equation $\frac{d^2y(t)}{dt^2} + 3 \frac{dy(t)}{dt} + 2y(t) = 2x(t) + \frac{dx(t)}{dt}$	6	3	3	1.1.3
<b>UNIT III</b>					
7a	Prove the following with respect to Z-Transforms a) Initial Value theorem b) Time shift c) ROC of an finite non-causal sequence is entire Z-plane except $Z=\infty$	10	3	2	1.1.3
7b	Find the Z-Transform of the following sequences and estimate the ROC a) $x(n) = 3^{n+1}u(n) - 2(1/2)^n u(-n - 1)$	10	3	3	1.1.3

Q.No	Questions	Marks	CO	BL	PI
	b) $x(n) = 3e^{-2n}u(n) + 2[4^n u(-n - 1)] + 5\delta(n)$ c) $x(n) = 2\delta(n - 3) - 2\delta(n + 3)$				
8a	Calculate the Inverse Z-Transform of $X(Z) = \frac{Z^3 + Z^2 + \frac{3}{2}Z + \frac{1}{2}}{Z^3 + \frac{3}{2}Z^2 + \frac{1}{2}Z} \text{ROC}  Z  < \frac{1}{2}$	10	3	3	1.1.3
8b	Find the impulse response of the system described by the difference equation $y(n) - \frac{1}{2}y(n - 1) = 2x(n - 1)$	10	4	3	2.1.2

### Blooms Level wise Marks Distribution

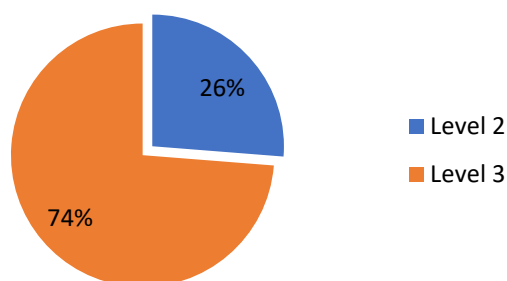

### Course Outcome wise Marks Distribution

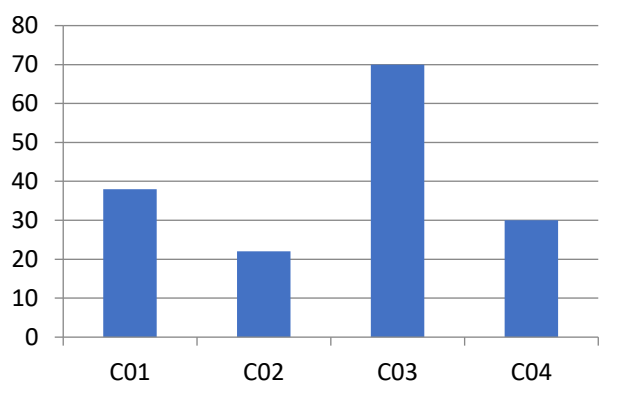

**BL – Bloom’s Taxonomy Levels (1- Remembering, 2- Understanding, 3 – Applying, 4 – Analysing, 5 – Evaluating, 6 - Creating)**

**CO – Course Outcomes**

**PO – Program Outcomes; PI Code – Performance Indicator Code**

# **Mechanical Engineering**

## **Model Question Papers**

### **For Undergraduate Program**

The model question papers are suggestive blueprints. The primary aim of these question papers is to bring clarity about the process of connecting questions to performance indicators and hence to course outcomes. Further, these question papers demonstrate how bloom's taxonomy can be used to understand the quality of question papers and their effectiveness in assessing higher order abilities. The structure of question papers, number of questions, choices given, time given for examination etc., can vary based on the practices of the University or college.

# Table of Contents

<b>Name of Course</b>	<b>Page No.</b>
1. Introduction to Finite Element Methods	ME1- ME5
2. Design of Thermal Systems	ME6- ME12
3. Manufacturing Processes	ME13- ME15
4. Machines & Mechanisms	ME16- ME20
5. Mechanical Vibrations	ME21- ME26
6. Mechanics of Materials	ME27- ME32

## Course Name: Introduction to Finite Element Methods

### Course Outcomes (CO):

At the end of the course the student should be able to:

1. Analyze bars and beams using variational principles and weighted residual techniques.
2. Establish shape functions for various elements to arrive at an elemental stiffness matrices and load vectors to obtain global equilibrium equation.
3. Idealize the problem based on various methodologies for performing finite element analysis.
4. Solve analytically the real time field problems related to Static structural, Non-linear, Linear buckling, Dynamic and Thermal analysis.
5. Perform analytical calculations pertaining to Drop/Impact test, Fatigue analysis and Composite structures.
6. Discuss the various experimental methodologies related to Non Destructive testing and draft the report.



**Model Question Paper**  
**Total Duration (H:M):3:00**  
**Course : Introduction to Finite Element Methods**  
**Maximum Marks :100**

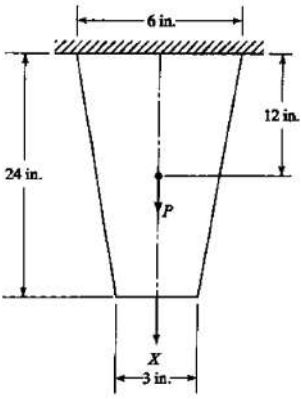
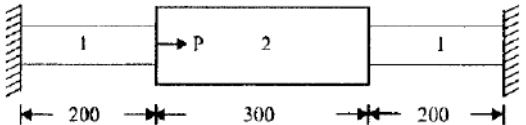

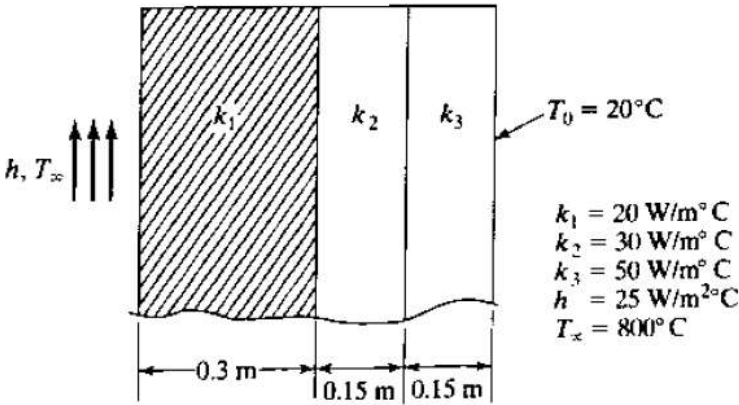
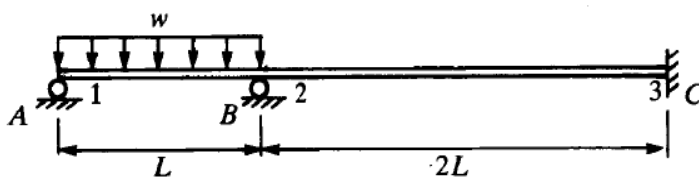
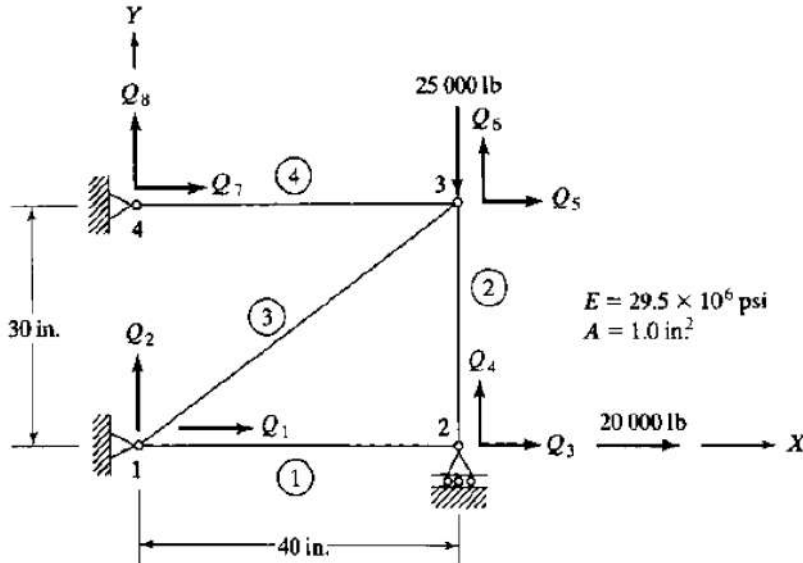
Q.No	Questions	Marks	CO	BL	PI
1a)	Differentiate between FEM, FDM, FVM and BEM. Explain which method is suited for analysis of polymer composite crack propagation along with software tool and justify.	10	CO1	L2	1.4.1
1b)	Using Rayleigh-Ritz method determine the expressions for deflection in a simply supported beam subjected to uniformly distributed load over entire span. Also calculate the percentage of error when RR method values are compared with analytical values.	10	CO1	L3	1.4.1
2a)	Consider a thin (steel) plate as shown in figure 2a. The plate has a uniform thickness $t=1$ in, Youngs modulus $E = 30 \times 10^6$ psi, and weight density $0.2836$ lb/in <sup>3</sup> . In addition to its self-weight, the plate is subjected to a point load $p = 100$ lb at its midpoint. a) Model the plate with two finite element points b) Write down the element stiffness matrices and element body force vectors. c) Assemble the structural stiffness matrix $K$ and global load factor $F$ . d) Using the elimination approach, solve for the global displacement vector $Q$ . e) Evaluate the stresses in each element.	10	CO 2	L3	2.3.1

Q.No	Questions	Marks	CO	BL	PI
	 <p style="text-align: center;">Fig.2a</p>				
2b)	Explain Different types of elements in FEM. Explain H type and P type method with the help of suitable example.	10	CO3	L2	2.4.1
3a)	Using Galerkin's method, establish an expression of the maximum deflection for a cantilever beam having length L, moment of inertia I and young's modulus E, subjected to point load P at the end. Also calculate the percentage of error when Galerkin's method values are compared with analytical values.	10	CO2	L2	2.4.3
3b)	Explain different mesh quality parameters. Discuss any five of them.	10	CO3	L2	2.4.1
<b>UNIT-II</b>					
4a)	For a given problem how a FEA engineer has to decide the following i) Element size ii) Element Type iii) Type of analysis to carry out iv) Linear or Non linear analysis v) How results are compared with real time scenario?	10	CO4	L3	2.4.1
4b)	<p>An axial load <math>P=200 \times 10^3 \text{ N}</math> is applied on a bar as shown in Fig. 4b. Using the penalty approach for handling boundary conditions, determine nodal displacements, stress in each material and reaction forces.</p>  <div style="border: 1px solid black; padding: 5px; width: fit-content; margin: 10px auto;"> <p>1 - <math>A_1 = 2400 \text{ mm}^2</math>; <math>E_1 = 70 \times 10^9 \text{ N/m}^2</math>  2 - <math>A_2 = 600 \text{ mm}^2</math>; <math>E_2 = 200 \times 10^9 \text{ N/m}^2</math></p> </div> <p style="text-align: center;">Fig. 4b</p>	10	CO3	L3	2.4.1
5a)	A composite wall consists of three materials, as shown in Fig 5a. The outer temperature is $T_o=20^\circ\text{C}$ . Convection heat transfer takes place on the inner surface of the wall with $T_\infty=800^\circ\text{C}$ and $h=25 \text{ W/m}^2\text{C}$ . Determine the temperature distribution in the wall.	10	CO4	L3	2.4.1

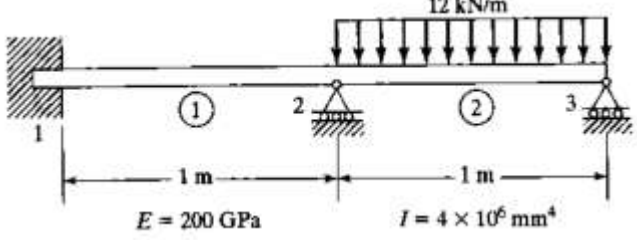
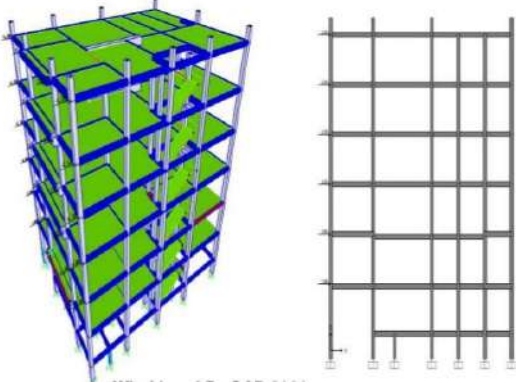
Q.No	Questions	Marks	CO	BL	PI
	 <p style="text-align: center;">Fig.5a</p>				
5b)	<p>The two span beam structure of Fig.5b is free to rotate at supports A and B and is fixed at joint C. Compute the rotations at supports A and B and the reactions at all supports. Construct Shear Force and Bending Moment Diagrams.</p>  <p style="text-align: center;">Fig. 5b</p>	10	CO2	L3	2.4.3
6a)	<p>Consider the four bar truss shown in Figure 6a. It is given that modulus of elasticity <math>E = 29.5 \times 10^6</math> psi and cross-sectional areas <math>A = 1 \text{ in.}^2</math> for all elements. Complete the following:</p> <ol style="list-style-type: none"> <li>Determine the element stiffness matrix for each element.</li> <li>Assemble the structural stiffness matrix <math>K</math> for the entire truss.</li> </ol>  <p style="text-align: center;">Fig. 6a</p>	10	CO3	L3	2.4.1



Q.No	Questions	Marks	CO	BL	PI
	Fig. 6a				
6b)	<p>For the beam shown in figure 6b, determine the support reactions and stresses in each element. Take <math>E=200 \text{ GPa}</math>, <math>I=4 \times 10^6 \text{ mm}^4</math>.</p>  <p>Fig. 6b</p>	10	CO4	L3	2.4.1
UNIT- III					
7a)	<p>Identify the boundary condition and type of analysis need to be carried out for multi storey building for cyclone hit condition as shown in figure 7a and justify your answer with suitable assumptions.</p>  <p>Fig.7a</p>	10	CO5	L4	2.2.3
7b)	<p>Idealize and express the methodology of solving the problem by FEA approach. Consider a person of 100 kg sitting on the bicycle as shown in figure 7b. Justify the answer with suitable assumptions.</p>  <p>Fig.7b</p>	10	CO5	L4	2.2.2

Q.No	Questions	Marks	CO	BL	PI
8a.	<p>The following figure 8a. shows a LCD TV which need to be analyzed for drop test. The average fall height of the LCD TV is 4 feet. Idealize and solve the problem with suitable assumptions.</p>  <p>Fig 8a</p>	10	CO6	L4	2.4.3
8b.	<p>Illustrate different types of analysis that can be possible with a FEA tool and elaborate the process of solving with suitable assumption on material and boundary conditions. The component is as shown in fig 8b.</p>  <p>Fig 8b</p>	10	CO6	L4	2.4.1

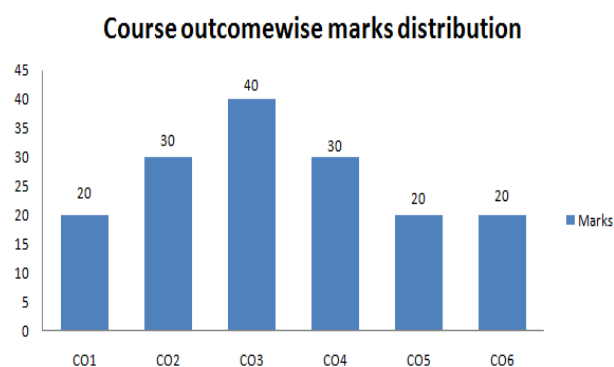
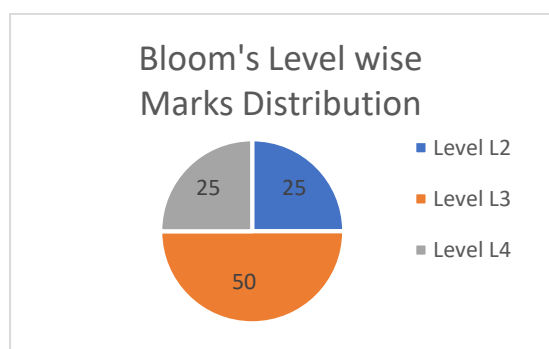

**BL – Bloom’s Taxonomy Levels (1- Remembering, 2- Understanding, 3 – Applying, 4 – Analysing, 5 – Evaluating, 6 - Creating)**

**CO – Course Outcomes PO – Program Outcomes; PI Code – Performance Indicator Code**

## Course Name: Design of Thermal Systems

### Course Outcomes (CO):

1. Select suitable heat exchanger, based on the heat transfer process, geometry and construction for a given application.
2. Design shell and tube heat exchanger for a given process requirement.
3. Develop mathematical models of the thermal systems like heat exchangers, condensers and evaporators.
4. Analyse design problems on piping system.
5. Develop mathematical statement of optimization for a given thermal system.
6. Optimize thermal systems using Lagrange multipliers method of optimization.
7. Analyse thermal systems using dynamic programming method.

**Model Question Paper**  
**Total Duration (H:M):3:00**  
**Course: Design of Thermal Systems**  
**Maximum Marks: 100**

*ii) Use of Heat transfer data Handbook is permitted.*

**Note:** *i) Answer any two full questions for Unit-1, any two full questions from Unit-II and any one full question from Unit-III*

Q. No.	Questions	Marks	CO	BL	PI
	Unit-I				
1 a	Name the specific heat exchanger construction type that may be used in each of the following application and justify your selection. a. Milk pasteurizing b. Power condenser c. Automotive radiator d. Marine oil cooler e. Air cooled condenser	10	CO1	L3	1.3.1
b	A two shell pass and two tube pass shell & tube heat exchanger is used to heat process fluid (water) from 30°C to 80°C. The mass flow rate of the process fluid is 8000kg/hr and that of the service fluid is 6000kg/hr, which is available at a temperature of 200°C. The overall heat transfer coefficient is 1500W/ m <sup>2</sup> K. Find out the outlet temperature of service fluid, and the area required for the heat transfer. After a long time of operation of the heat exchanger, it is found that the outlet temperature of the	10	CO2	L3	1.4.1

	process fluid is only 70°C. Find the fouling resistance developed during this period. Cp of the service fluid = 2.8kJ/Kg K Cp of the process fluid =4.2kJ/Kg K				
2. a	What are the different kinds of spiral plate heat exchangers and what are their limitations?	10	CO1	L2	1.3.1
b.	A counter flow shell and tube heat exchanger is used to cool engine oil flowing through the tube at 0.25kg/s, the specific heat of oil is 2.2kJ/kg K. This oil is cooled by the water, which flows at 0.3kg/s. The oil enters at 560K and leaves at 340K. The cooling water enters at 298K. Find the length of the tube if the heat transfer coefficient from oil to tube surface is 2340W/m <sup>2</sup> K, and from tube surface to water is 6215W/m <sup>2</sup> K. The mean diameter of the tube is 18mm.	10	CO2	L3	1.4.1
3.a	A process industry uses a shell & tube heat exchanger, the shell specifications are as follows, Length of shell: $L_s = 4.5$ m Shell diameter ; $D_s = 500$ mm Outside diameter of tube: $D_o = 24.5$ mm Tube pitch ( square) : $P_i = 32.5$ mm Baffle spacing: $L_B = 132$ mm The fluid has the following specifications , Mass flow rate $m_i = 5.2$ kg/s Density $\rho = 820$ kg/m <sup>3</sup> Specific heat capacity $C_p = 2.24$ kJ/kg K Dynamic viscosity $\mu = 0.384 \times 10^{-3}$ Ns/m <sup>2</sup> Thermal conductivity $k = 0.125$ W/ mK. By Kern's method, find shell side heat transfer coefficient and pressure drop.	10	CO2	L3	1.4.1
b.	A shell & tube heat exchanger has steel pipes of 32mm outer diameter and 26mm inner diameter. Ethylene glycol flows in tubes having a heat transfer coefficient of 1680W/m <sup>2</sup> K and a fouling resistance of 0.00065 m <sup>2</sup> K/W. Water flows on shell side having a heat transfer coefficient of 3215W/m <sup>2</sup> K, and a fouling resistance of 0.0003 m <sup>2</sup> K/W. The thermal conductivity of tube is 68 W/ m K. Find the overall heat transfer coefficient of the heat exchanger.	10	CO2	L3	1.4.1
	Unit-II				
4 a.	Between two stages of air compression, the air is to be cooled from 95°C to 10°C. The facility to perform this cooling, shown in Fig Q4 (a), first cools the air in a precooler and then in a refrigeration unit. Water passes through the condenser of the refrigeration unit, then into the precooler, and finally to a cooling tower, where heat is rejected to the atmosphere. The flow rate of compressed air is 1.2 kg/s, and the specific heat is 1.0 kJ/(kg K). The flow rate of water is 2.3 kg/s, and	10	CO5	L4	2.1.2

its specific heat is 4.19 kJ/(kg K). The water leaves the cooling tower at a temperature 24°C. The system is to be designed for minimum first cost, where this first cost comprises the cost of the refrigeration unit, precooler, and cooling tower, designated  $x_1$ ,  $x_2$  and  $x_3$  respectively, in dollars. The expressions for these costs are

Refrigeration unit:  $x_1 = 48q_1$

Precooler:  $x_2 = 50q_2/(t_3-t_1)$

where the equation is applicable when  $t_3 > t_1$

Cooling tower:  $x_3 = 25q_3$

where the  $q$ 's are rates of heat transfer in kilowatts, as designated in figure. The compression power  $P$  kW required by the refrigeration unit is  $0.25q_1$ , and both  $q_1$  and the compression power must be absorbed by the condenser cooling water passing through the refrigeration unit.

Develop (a) the objective function and (b) the constraint equations for optimization to provide minimum first cost

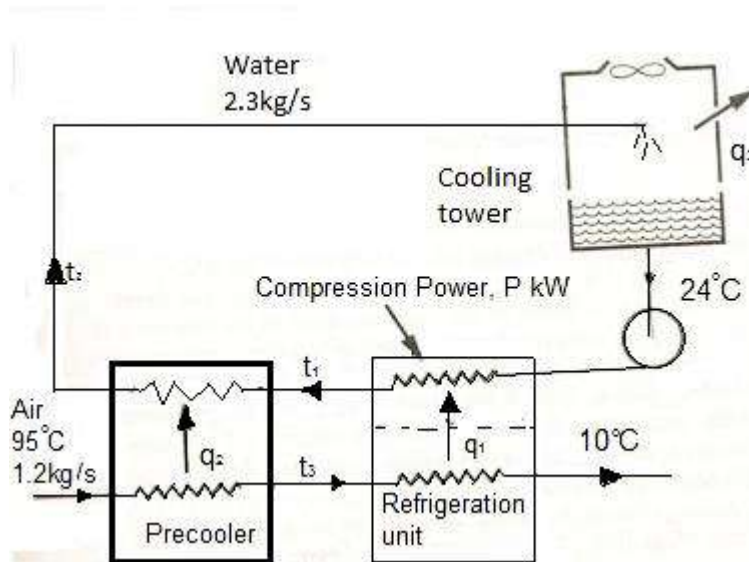
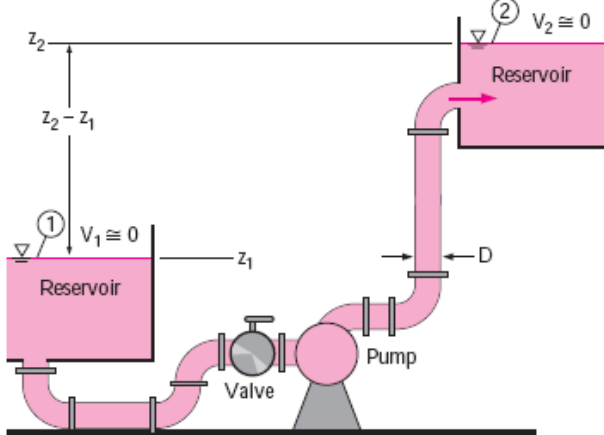

Fig. Q4(a): Air cooling system

b.	Oil at 20°C ( $\rho = 888 \text{ kg/m}^3$ and $\mu = 0.800 \text{ kg/ms}$ ) is flowing steadily through a 0.05 m diameter 40 m long pipe. The pressure at the pipe inlet and outlet are measured to be 745 and 97 kPa, respectively. Determine the flow rate of oil through the pipe assuming the pipe is (a) horizontal, (b) inclined 15° upward, (c) inclined 15° downward. Also verify that the flow through the pipe is laminar.	10	CO4	L3	1.4.1
5 a.	A counter flow heat exchanger cools 5 kg/s of oil, $C_p = 2.4 \text{ kJ/kg K}$ , with water that has a flow rate of 7.5 kg/s. The specific heat of water is 4.19 kJ/kg K. Under the original operating conditions the oil is cooled from 75°C to 40°C when water enters at 25°C. To what temperature will the oil	10	CO3	L3	1.4.1

	<p>be cooled if it enters at 65°C and there is no change in the entering water temperature, the flow rates of either fluid or the heat transfer coefficients?</p>																
<p>b</p>	<p>A water pump is used to pump from one large reservoir to another large reservoir that is at a higher elevation. The free surfaces of both reservoirs are exposed to atmospheric pressure, as sketched in Fig. 5(b). The dimensions and minor loss coefficients are provided in the figure. The pump's performance is approximated by the expression <math>H_{available} = H_o - aV^2</math>, where shutoff head <math>H_o=24.4</math> m of water column, coefficient <math>a = 0.0678</math> m/Lpm<sup>2</sup>, available pump head <math>H_{available}</math> is in units of meters of water column, and capacity <math>V</math> is in units of liter per minute. Estimate the capacity delivered by the pump.</p> <p style="text-align: center;"> <math>z_2 - z_1 = 7.85</math> m (elevation difference)  <math>D = 2.03</math> cm (pipe diameter)  <math>K_{L, entrance} = 0.50</math> (pipe entrance)  <math>K_{L, valve} = 17.5</math> (valve)  <math>K_{L, elbow} = 0.92</math> (each elbow—there are 5)  <math>K_{L, exit} = 1.05</math> (pipe exit)  <math>L = 176.5</math> m (total pipe length)  <math>\epsilon = 0.25</math> mm (pipe roughness)         </p>  <p style="text-align: center;">Fig. Q5(b): Pumping System</p>	<p>10</p>	<p>CO4</p>	<p>L3</p>	<p>1.4.1</p>												
<p>6 a</p>	<p>The performance data for a centrifugal water pump are shown in Table Q6(a) for water at 20°C (Lpm = Litre per minute). (a) For each row of data, calculate the pump efficiency (percent). Show all units and unit conversions for full credit. (b) Estimate the volume flow rate (Lpm) and net head (m) at the BEP of the pump.</p> <p style="text-align: center;">Table Q6(a): Pump performance</p> <table border="1" style="margin-left: auto; margin-right: auto;"> <thead> <tr> <th>V, LPM</th> <th>H, m</th> <th>Bp, W</th> </tr> </thead> <tbody> <tr> <td>0.0</td> <td>47.5</td> <td>133</td> </tr> <tr> <td>6.0</td> <td>46.2</td> <td>142</td> </tr> <tr> <td>12.0</td> <td>42.5</td> <td>153</td> </tr> </tbody> </table>	V, LPM	H, m	Bp, W	0.0	47.5	133	6.0	46.2	142	12.0	42.5	153	<p>10</p>	<p>CO4</p>	<p>L3</p>	<p>1.4.1</p>
V, LPM	H, m	Bp, W															
0.0	47.5	133															
6.0	46.2	142															
12.0	42.5	153															

		18.0	36.2	164					
		24.0	26.2	172					
		30.0	15.0	174					
		36.0	0.0	174					
b	A double pipe heat exchanger serves as an oil cooler with oil flowing in one direction through the inner tube and cooling water in the opposite direction through the annulus. The oil flow rate is 0.63 kg/s, oil has a specific heat of 1.68 kJ/kg K, the water flow rate is 0.5 kg/s and its specific heat is 4.19 kJ/kg K. In a test of the prototype, oil entering at 78°C was cooled to 54°C when the entering water temperature was 30°C. The possibility of increasing the area of heat exchanger by increasing the length of the double pipe is to be considered. If the flow rates, fluid properties and entering temperatures remain unchanged, what will be the expected outlet temperature of the oil be if the area is increased by 20 percent?	10	CO3	L3	1.4.1				
	Unit-III								
7	A solar collector and storage tank is to be optimized to achieve minimum first cost. During the day the temperature of water in the storage vessel is elevated from 25°C (the minimum useful temperature) to $t_{max}$ . The collector receives 260 W/m <sup>2</sup> of solar energy; but there is heat loss from the collector to the ambient air by convection. The convective heat transfer coefficient is 2 W/m <sup>2</sup> K, and the average temperature difference during the 10 hour day is $(25+t_{max}) / 2$ minus the ambient temperature of 10°C. The energy above the minimum useful temperature of 25°C that is to be stored in the vessel during the day is 200,000 kJ. The density of water is 1000 kg/m <sup>3</sup> , and its specific heat is 4.19 kJ/kg K. The cost of the solar collector is 20A units, where A is the area in m <sup>2</sup> and the cost of the storage vessel is 101.5V, where V is the volume in cubic meters. (a) Using A and V as the variables, set up the objective function and constraint to optimize the first cost. (b) Develop the Lagrange multiplier equations and verify that they are satisfied by $V=1.2\text{m}^3$ and $A=29.2\text{m}^2$	20	CO6	L4	3.3.1				

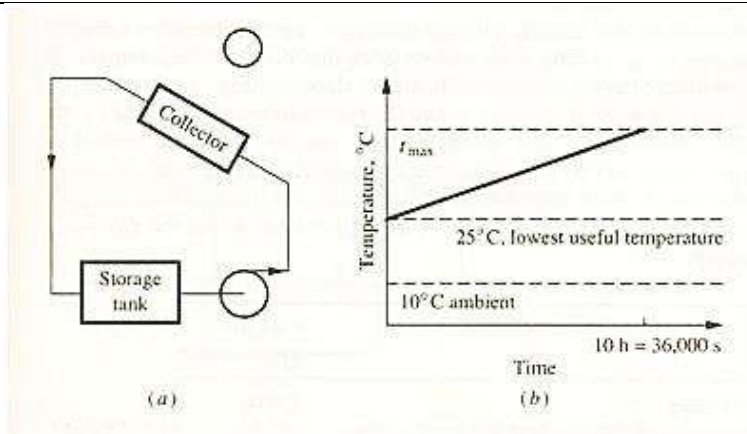

Fig Q7: Solar water heating system

8 The total pressure drop from point 1 to point 5 in the multi-branch duct system shown in Fig. Q8 below is to be 500 Pa. Table Q8, presents the costs for various duct sizes in each of the sections as a function of the pressure drop in the section. Use dynamic programming to determine the pressure drop in each section that results in the minimum total cost of the system.

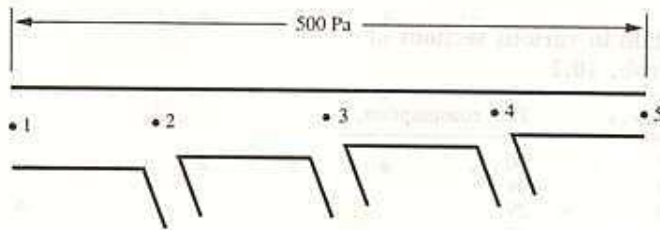

Fig.Q8 : Duct system

Table Q8 : Pressure drop and costs of sections of duct

Section	Pressure drop, Pa	Cost, \$
1-2	100	222
	150	205
	200	193
2-3	100	180
	150	166
	200	157
3-4	100	135
	150	125
	200	117
4-5	100	93
	150	86
	200	81

20

CO7

L4

3.3.1



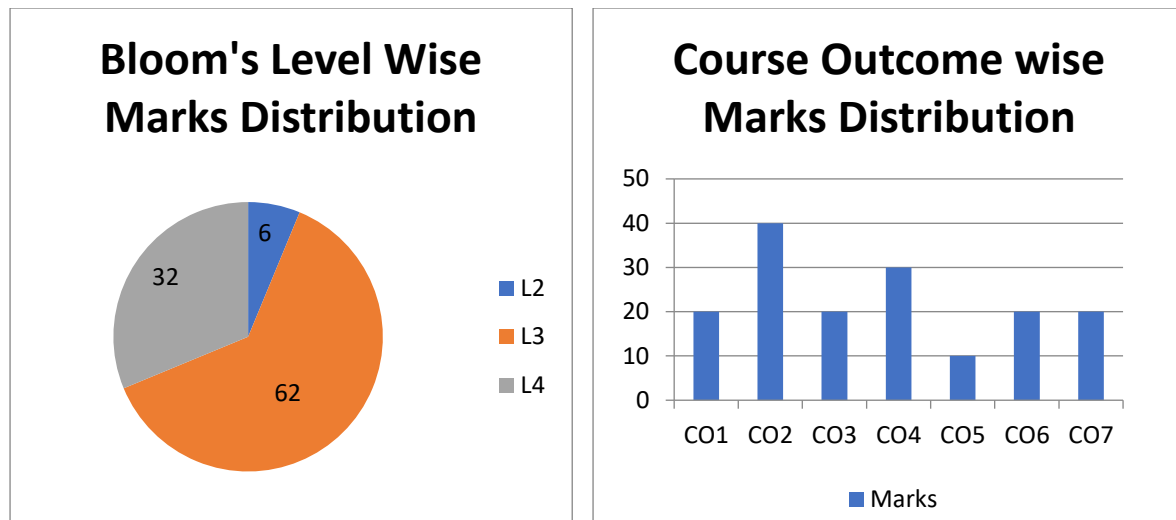

**BL – Bloom's Taxonomy Levels (1- Remembering, 2- Understanding, 3 – Applying, 4 – Analysing, 5 – Evaluating, 6 - Creating)**

**CO – Course Outcomes**

**PO – Program Outcomes; PI Code – Performance Indicator Code**

## Course Name: Manufacturing Processes

### Course Outcomes (CO):

1. Classify manufacturing processes & enumerate the process steps involved in a sand casting process and their applications.
2. Recommend a suitable moulding /casting method (sand/special) & a melting furnace to cast given auto components.
3. Enumerate cleaning/fettling operations and discuss various types of casting defects, possible causes for their occurrence, detection methods and suggest remedies.
4. Suggest a suitable welding process (arc welding, ultrasonic welding, electron beam welding, laser beam welding etc) for a given precision welding job.
5. Illustrate the fundamental principles of metal cutting processes and specify suitable machine tools (traditional/CNC) and develop process plan/part programming for producing given component.
6. Recommend a suitable forming process for a given component.
7. Recommend a suitable non- traditional/micro-machining/high speed machining method for a stated application.

**Model Question Paper**  
**Total Duration (H:M):3:00**  
**Course: Manufacturing Processes**  
**Maximum Marks: 100**

Q.No	Questions	Marks	CO	BL	PI
1a	Manufacturing processes are classified as, i) Processing operations and ii) Assembly operations Mention sub-classifications under these two categories with suitable examples.	6	CO1	L2	1.4.1
1b	A broken railway track needs welding on-site. Recommend a suitable process & outline its working principle.	6	CO4	L3	1.3.1
1c	Differentiate between Brazing, Soldering and Welding with the following aspects, i) Temperature ii) Type of material to be joined iii) Surface finish and iv) Strength	8	CO4	L2	1.3.1
2a	Discuss the criteria for selection of manufacturing processes.	6	CO1	L2	1.4.1
2b	A precision foundry needs to produce IC engine pistons. Suggest suitable process and explain the procedure with neat sketch.	6	CO2	L3	1.3.1
2c	Explain the post processes of casting, fettling-cleaning and finishing of castings.	8	CO3	L2	1.3.1
3a	Enumerate the steps involved in sand casting.	6	CO2	L2	1.3.1

Q.No	Questions	Marks	CO	BL	PI
3b	A pattern shop has received order to make a wooden pattern for making sand castings. Discuss various pattern allowances to be considered by him to produce the required pattern.	6	CO2	L3	1.3.1
3c	With neat sketch, discuss the working principle of investment casting process and list the advantages & limitations of it.	8	CO2	L2	1.3.1
4a	Draw Merchant's force diagram. State the assumptions made in the development of such a diagram.	6	CO5	L2	2.3.2
4b	Interpret the program syntax. N10 G28 U0 W0; N20 T0101; N30 G00 X35 Z2; N40 G00 X30 M03 S1500; N50 G01 Z64 M08 F0.1;	6	CO5	L3	1.4.1
4c	A drilling operation is performed on a steel part using a 10mm diameter twist drill with point angle $118^{\circ}$ . The hole is blind hole with depth of 60mm. Cutting speed=15m/min and feed =0.20mm/rev. Determine, i) Cutting time of the operation ii) Material removal rate	8	CO5	L3	2.1.3
5a	Considering the suitable example, explain open and closed loop control system.	6	CO5	L2	1.4.1
5b	Enumerate the advantages and disadvantages of CNC machines.	6	CO5	L2	1.4.1
5c	In orthogonal cutting operation on a material with the shear yield strength of 250N/mm <sup>2</sup> , the following data is observed. Rake angle= $20^{\circ}$ Uncut chip thickness= 0.3mm Width of chip= 1.5mm Chip thickness ratio= 0.4 Friction angle= $40^{\circ}$ Determine, i) The shear angle ii) The cutting force component iii) The resultant force on the tool	8	CO5	L3	2.1.3
6a	When do you recommend the climb milling and up milling? Explain the same with diagram.	6	CO5	L3	1.4.1
6b	A typical tool signature of single point cutting tool is 0-7-6-8-15-16-0.8. Interpret this and show with neat sketch of the tool.	6	CO5	L2	2.3.1
6c	A peripheral milling operation is performed on the top surface of a rectangular work part which is 200mm long and 40mm wide. The milling cutter, which is 90mm in diameter and has 13 teeth, overhangs the width of the part on both sides. Cutting speed = 70m/min, chip load = 0.2mm/tooth depth of cut = 6mm	8	CO5	L3	1.4.1

Q.No	Questions	Marks	CO	BL	PI
	Determine: i) The actual machining time to make one pass ii) The material removal rate.				
7a	Differentiate between bulk deformation & sheet metal working.	6	CO6	L2	2.1.2
7b	Explain the advantages of thread rolling over thread cutting (machining).	6	CO6	L2	1.3.1
7c	Determine the minimum force capacity press to perform the blanking operation on 1.5mm thick mild steel sheet with shear strength of 360N/mm <sup>2</sup> . The blanking profile is rectangle with 50×100mm dimensions. Also find the total force required if there were two 13mm diameter holes to be pierced simultaneously in the previous station along with blanking.	8	CO6	L3	1.3.1
8a	Explain in what cases do you prefer non-traditional machining process suitable.	6	CO7	L3	1.4.1
8b	Explain electric discharge machining process principle with neat sketch and state its applications.	6	CO7	L2	1.4.1
8c	Additive manufacturing is the key component for the “future of manufacturing”. Explain your understanding of the statement and outline two process that are in use today.	8	CO7	L3	2.1.3

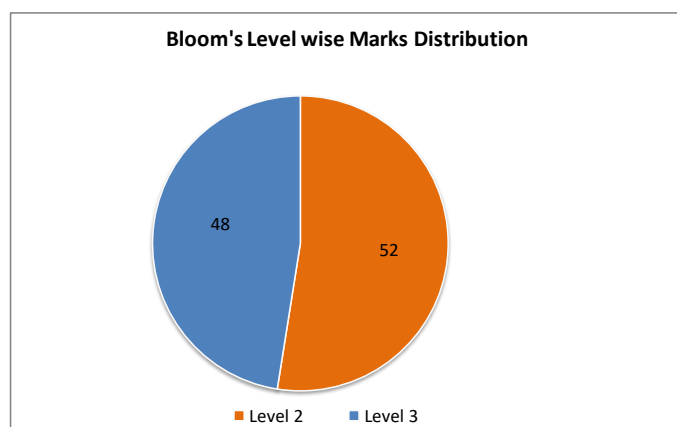

**BL – Bloom’s Taxonomy Levels (1- Remembering, 2- Understanding, 3 – Applying, 4 – Analysing, 5 – Evaluating, 6 - Creating)**

**CO – Course Outcomes**

**PO – Program Outcomes; PI Code – Performance Indicator Code**

## Course Name: Machines & Mechanisms

### Course Outcomes (CO):

1. Analyze the given machine/mechanism for their type and mobility
2. Determine the velocity and acceleration of links in the mechanism using graphical and analytical methods.
3. Carry out the static and dynamic force analysis for a given mechanism.
4. Formulate the equations for kinematic and dynamic analysis of gear and gear trains for a given gear arrangement.
5. Analyze the dynamic forces and couples on rotating and reciprocating components of machines to compute the magnitude and direction of balancing mass.
6. Develop a cam profile for a given follower motions.
7. Ascertain the gyroscopic and centrifugal couple for a given application

**Model Question Paper**  
**Total Duration (H:M): 3:00**  
**Course: Machines & Mechanisms (15EMEC204)**  
**Maximum Mark: 100**

**Note:** i) Answer any two full questions for Unit-1, any two full questions from Unit-II and any one full question from Unit-III

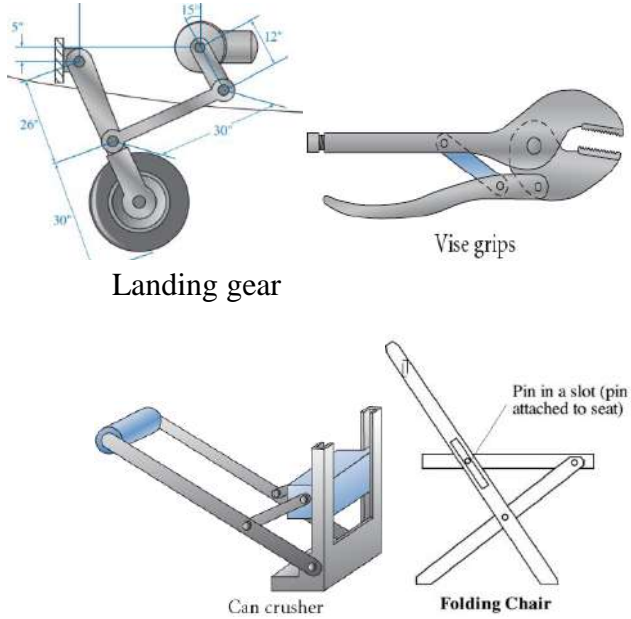
Q.No.	Questions	Marks	CO	BL	PI
	<b>Unit 1</b>				
1a)	<p>Draw the kinematic diagram for the mechanisms shown in the Fig.Q1a (i to iv). Compute the mobility.</p>  <p style="text-align: center;">Fig.Q1a (i to iv)</p>	10	CO1	L3	2.1.2

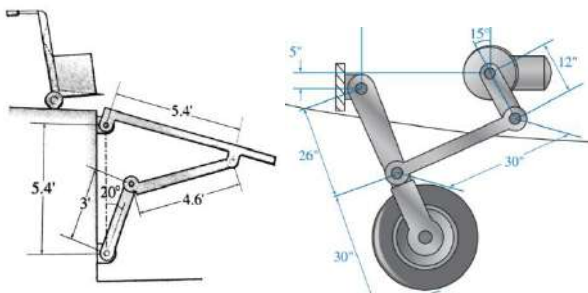
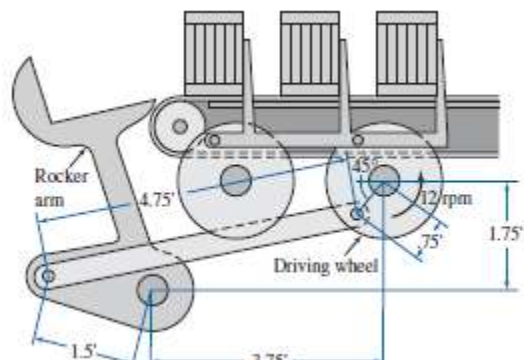
<p>1b)</p>	<p>For the mechanisms shown in the Fig. Q1b i) and ii), locate all the instantaneous centers.</p>  <p>Fig Q1b.i) Self-locking brace Fig Q1b.ii) Landing gear</p>	<p>10</p>	<p>CO2</p>	<p>L2</p>	<p>2.1.3</p>
<p>2a)</p>	<p>Three links in a kinematic chain move relatively to each other. Prove that they have three instantaneous centers and lie in a straight line</p>	<p>8</p>	<p>CO2</p>	<p>L2</p>	<p>1.3.1</p>
<p>2b)</p>	<p>The gearbox shaft and propeller shaft of an automobile are connected by a universal joint. Obtain the expression for ratio of output shaft speed to input shaft speed. analyze the conditions when propeller shaft will have i) maximum speed ii) minimum speed and iii) both shafts have equal speeds.</p>	<p>12</p>	<p>CO1</p>	<p>L3</p>	<p>1.3.1</p>
<p>3a)</p>	<p>Describe with neat sketch the mechanism used in the automobile steering system and obtain the expression for condition of correct steering.</p>	<p>6</p>	<p>CO1</p>	<p>L2</p>	<p>1.3.1</p>
<p>3b)</p>	<p>The mechanism shown in the Fig. Q3b) is used to feed cartons to a labeling machine and, at the same time, to prevent the stored cartons from moving down. At full speed, the driveshaft rotates clockwise with an angular velocity of 200 rpm. At the instant shown, determine the acceleration of the rocker arm that rotates and lowers the parts.</p>  <p>Fig. Q 3b)</p>	<p>14</p>	<p>CO2</p>	<p>L4</p>	<p>2.1.3</p>
<p><b>Unit 2</b></p>					

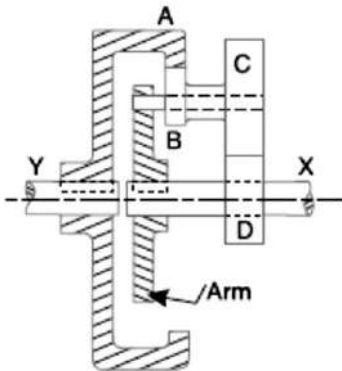
4a)	A shaft has 3 disturbing masses in the single plane with radii of rotation $r_1$ , $r_2$ and $r_3$ and angular positions $\theta_1$ , $\theta_2$ and $\theta_3$ . Discuss how the system will be balanced by adding another balancing mass in the same plane.	8	CO5	L2	1.4.1
4b)	Determine the required input torque on the crank AB of the reciprocating engine mechanism for the static equilibrium when applied piston load is 1000 N. The lengths of crank AB and connecting rod BC are 100 mm and 300 mm respectively and crank has turned through $60^\circ$ from I.D.C.	12	CO3	L3	2.4.1
5a)	Explain with neat sketch i) equilibrium of two force member ii) equilibrium of three force member iii) member with two forces and applied torque.	8	CO3	L2	1.2.1
5b)	An over drive for a vehicle consists of an epicyclic gear train, as shown in Fig. Q5b), with compound planets B-C. B has 15 teeth and meshes with an annulus A which has 60 teeth. The planet C has 20 teeth and meshes with the sun wheel D which is fixed. The annulus is keyed to the propeller shaft Y which rotates at 740 rad/s. The spider which carries the pins upon which the planets revolve, is driven directly from main gear box by shaft X, this shaft being relatively free to rotate with respect to wheel D. Find the speed of shaft X, when all the teeth have the same module. When the engine develops 130 kW, what is the holding torque on the wheel D? Assume 100 per cent efficiency throughout.	12	CO4	L4	2.1.3
 <p>Fig Q 5b) Epicyclic gear train</p>					
6a)	The pinion on the lay shaft drives gear on the main shaft of automobile gear box. The contact between pair of involute teeth begins at one point and ends at other point. Obtain an expression for path of contact between pair of involute teeth.	8	CO4	L3	1.3.1

6b)	The A, B, C & D are four masses carried by a rotating shaft at radius 100, 125, 200 & 150 mm respectively. The planes in which masses revolve are spaced 600 mm apart & masses B, C & D are 10, 5 and 4 kg respectively. Find the required mass A & relative angular positions of the four masses to keep the shaft in the dynamic balance.	12	CO5	L3	2.4.1
<b>Unit 3</b>					
7a)	In a single cylinder automotive engine spherical follower is operated by a disc cam. If the follower moves with simple harmonic motion then obtain an expression for velocity and acceleration during its out and return strokes.	8	CO6	L2	1.3.1
7b)	Design a cam to raise a valve with simple harmonic motion through 50 mm in 1/3 of a revolution, keep it fully raised through 1/12 revolution and to lower it with harmonic motion in 1/6 revolution. The valve remains closed during the rest of the revolution. The diameter of the roller is 20 mm and the minimum radius of the cam is 25 mm. The diameter of the camshaft is 25 mm. The axis of the valve rod passes through the axis of the camshaft. If the camshaft rotates at uniform speed of 100 rpm, find the maximum velocity and acceleration of a valve during raising and lowering.	12	CO6	L3	2.1.2
8a)	Discuss with a neat sketch the axis of spin, axis of couple, axis of precession and precessional angular motion by considering the disc is spinning about X-axis. Obtain the expression for precessional angular motion.	8	CO7	L2	1.2.1
8b)	The turbine rotor of a ship has a mass of 3500 kg. It has a radius of gyration of 0.45 m and a speed of 3000 rpm clockwise when looking from stern. Determine the gyroscopic couple and its effect upon the ship: i) when the ship is steering to the left on a curve of 100 m radius at a speed of 36 km/h ii) when the ship is pitching in a simple harmonic motion, the bow falling with its maximum velocity. The period of pitching is 40 seconds and the total angular displacement between the two extreme positions of pitching is 12 degrees.	12	CO7	L3	1.2.1



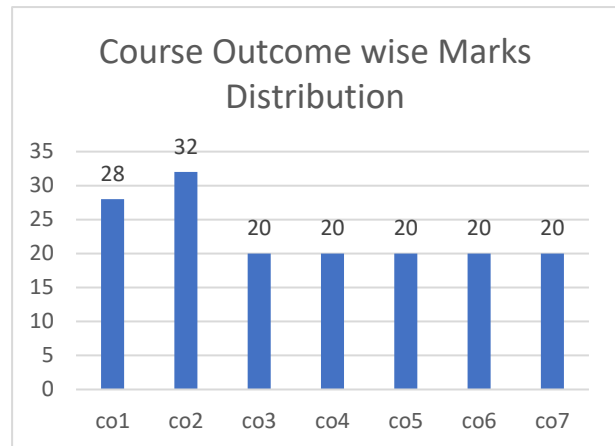
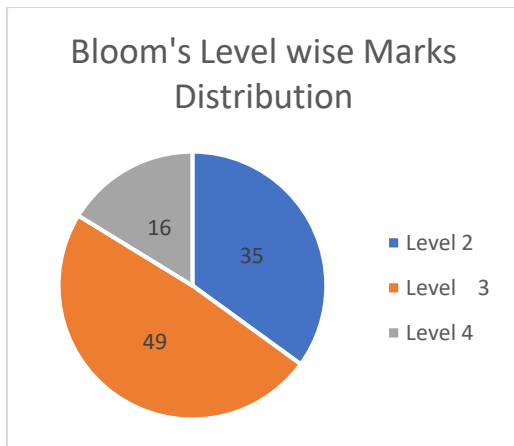

**BL – Bloom's Taxonomy Levels (1- Remembering, 2- Understanding, 3 – Applying, 4 – Analysing, 5 – Evaluating, 6 - Creating)**

**CO – Course Outcomes**

**PO – Program Outcomes; PI Code – Performance Indicator Code**

## Course Name: Mechanical Vibrations

### Course Outcomes (CO):

1. Determine the natural frequency of undamped free vibrations of single degree of freedom systems by formulating mathematical model of physical systems.
2. Analyse the response of damped systems for different amount of damping and compute the natural frequency of damped free vibration of mechanical systems.
3. Solve a problem related to whirling of shaft with rotor having some eccentricity.
4. Investigate the response of vibrating systems under forced harmonic excitations and explain the effect of magnification factor, vibration isolation and transmissibility on vibrating system.
5. Evaluate the natural frequencies and mode shapes of two degrees of freedom vibration systems and design vibration absorbers.
6. Determine the natural frequencies and mode shapes for multi-degree of freedom vibrating systems.
7. Explain vibration analysis techniques and noise measuring techniques to diagnose faults in machinery.

**Model Question Paper**  
**Total Duration (H:M): 3:00**  
**Course: Mechanical Vibrations**  
**Maximum Marks: 100**

**Note:** i) Answer any two full questions for Unit-1, any two full questions from Unit-II and any one full question from Unit-III

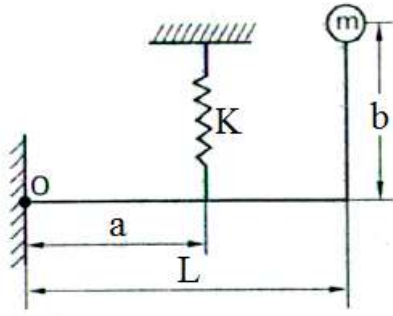
Q. No.	Questions	Marks	CO	BL	PI
<b>Unit I</b>					
1 a)	<p>An inverted pendulum as shown in Fig. Q 1(a) is pivoted at point O. Assume small oscillations and neglect the mass of the rod. Obtain the condition for the system to vibrate.</p> <p>Develop 1 and 2 dof mathematical model of a car</p>  <p style="text-align: center;">Fig.Q1(a)</p>	10	CO1	L3	2.1.3
1 b)	<p>A gun barrel shown in Fig. Q 1(b) having mass 560 kg is designed with the following data. Initial recoil velocity of 36 m/s and recoil distance on firing 1.5m. Determine i) Spring constant ii) Critical damping coefficient</p>	10	CO2	L3	2.1.3

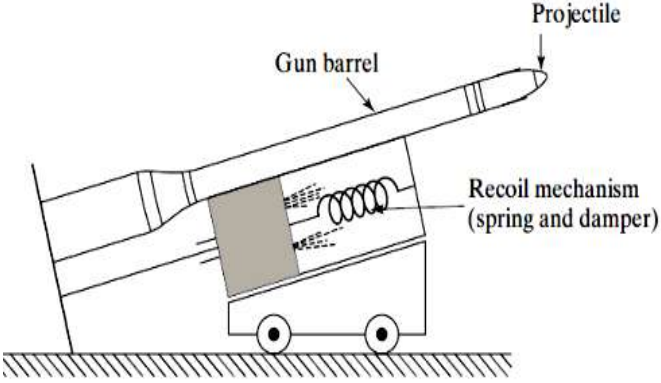
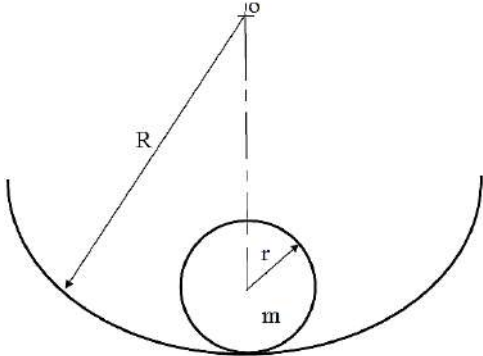
	<p>of the dashpot which is engaged at the end of the recoil stroke. iii) Time required for the barrel to return to a position of 0.12 m from its initial position.</p>  <p style="text-align: center;">Fig.Q1(b)</p>				
2 a)	<p>A cylinder of mass 'm' and radius 'r' rolls without slipping on a cylindrical surface of radius R as shown in Fig. Q 2(a). Find the natural frequency for small vibrations.</p>  <p style="text-align: center;">Fig.Q2(a)</p>	10	CO1	L3	2.1.3
2 b)	<p>A rotor of mass 4 kg is mounted midway between bearings which may be assumed to be simple supports. The bearing span is 480 mm. The shaft is of 9 mm diameter and is horizontal. The center of gravity of the disc is displaced 3 mm away from the geometric center of rotor. The equivalent viscous damping at the center of the disc and shaft may be assumed as 49 N-S/m. The shaft rotates at 760 rpm. Take <math>E=2 \times 10^{11} \text{ N/m}^2</math>. Determine</p> <p>i) The critical speed of the shaft                      ii) Deflection of the shaft  iii) Dynamic load on the bearings iv) The maximum stress in the shaft.  v) Identify the parameters to reduce the stress in the shaft. Use any one parameter and reduce the stress to its 50%.</p>	10	CO3	L4	2.1.3
3 a)	<p>Explain any four instruments used for measuring, assessing and analyzing the noise output of machines.</p>	08	CO7	L2	1.4.1
3 b)	<p>A railroad car of mass 2,000 kg traveling at a velocity 10 m/s is stopped at the end of the tracks by a spring-damper system, as shown in Fig. Q3(b). The stiffness of each spring (<math>K/2</math>) is 40 N/mm and the damping constant is 20N-s/mm. Determine i) Undamped and damped natural frequency ii) Damping factor    iii) The maximum displacement of the car after engaging the springs and damper.</p>	12	CO2	L4	2.1.2

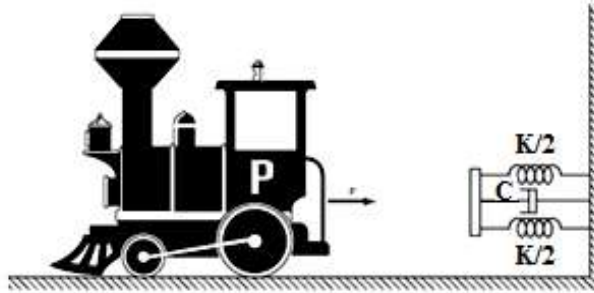

Fig.Q3(b)

Unit II

4 a) An automobile trailer that can vibrate in the vertical direction while traveling over a rough road is modeled as shown in Fig. Q 4(a). It has a vertical natural frequency of 100 cpm. It is driven along a road whose elevation varies approximately by a sine wave of amplitude 50 mm. The distance along the road between the peaks is 30 m. The damping ratio of shock absorbers is 0.2. Determine the amplitude of vibration of the car at a speed of 50 km/hr. Suggest possible methods of improving the design for a more comfortable ride of the passengers.

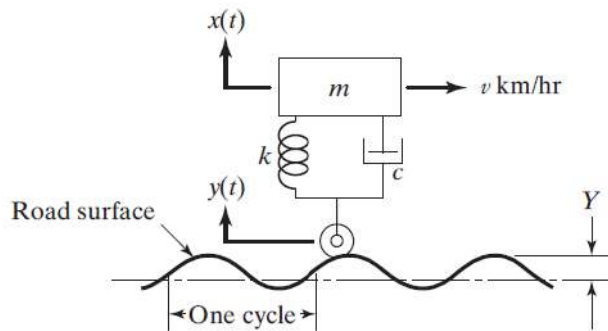

Fig. Q 4(a)

10

CO4

L4

2.1.3

4 b) Determine the two natural frequencies for small oscillations of the pendulum shown in Fig. Q 4(b). Assume the rods are mass less and rigid. Take  $K = 1 \text{ kN/m}$ ,  $L = 0.75 \text{ m}$ ,  $a = 0.4 \text{ m}$ ,  $m_1 = 3 \text{ kg}$ ,  $m_2 = 5 \text{ kg}$ .

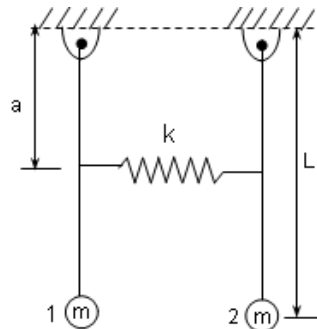

Fig. Q 4(b)

10

CO5

L3

2.1.2

5 a) A machine of mass 150 kg supported on springs of total stiffness 1050 kN/m is modelled as shown in Fig. Q 5(a). It has an excitation force of 525 N at a speed of 6000 rpm. The damping factor of the system is 0.3. Determine, i) The amplitude caused by the unbalance and its phase angle ii) The transmissibility iii) The actual force transmitted and its phase angle.

10

CO4

L3

3.1.6

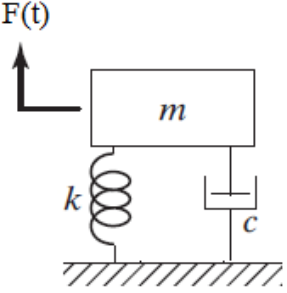
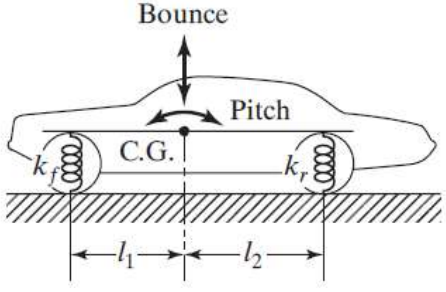
	 <p style="text-align: center;">Fig. Q 5(a)</p>				
<p>5 b)</p>	<p>Model the car shown in Fig. Q 5(b) and determine the pitch (angular motion) and bounce (up-and-down linear motion) frequencies and the location of oscillation centers (nodes) with the following data. Mass (<math>m</math>) = 1000 kg, radius of gyration (<math>r</math>) = 0.9 m, distance between front axle and C.G. (<math>l_1</math>) = 1.0 m, distance between rear axle and C.G. (<math>l_2</math>) = 1.5 m, front spring stiffness (<math>k_f</math>) = 18 kN/m, rear spring stiffness (<math>k_r</math>) = 22 kN/m.</p>  <p style="text-align: center;">Fig. Q 5(b)</p>	10	CO5	L3	2.3.1
<p>6 a)</p>	<p>A machine weighing 750 N is mounted on springs of 1200 kN/m stiffness with damping factor of 0.2. A piston within the machine weighing 20 N has a reciprocating motion with a stroke of 0.075 m and a speed of 3000 rpm. Assume the motion of the piston to be harmonic. Determine,</p> <p>i) Amplitude of motion of the machine and its phase angle w.r.t. the exciting force. ii) The transmissibility, the force transmitted to the foundation and its phase angle w.r.t. the exciting force. iii) Has the vibration isolation achieved, if so how? iv) Explain the effect of increasing the operating speed of the system on isolation.</p>	08	CO4	L4	2.1.3
<p>6 b)</p>	<p>The vibration absorber is shown in Fig. Q 6(b). Show that amplitude of vibration for the main system is given by</p> $X_1 = \frac{(K_2 - m_2 \omega^2) F_0}{m_1 m_2 \omega^4 - [m_1 k_2 + m_2 (k_1 + k_2)] \omega^2 + k_1 k_2}$ <p>A reciprocating machine weighing 25 kg running at 6000 rpm after installation has natural frequency very close to the forcing frequency of vibrating system. Design dynamic absorber of the nearest frequency of the system which is to be at least 20% from the excitation frequency.</p>	12	CO5	L3	2.1.3

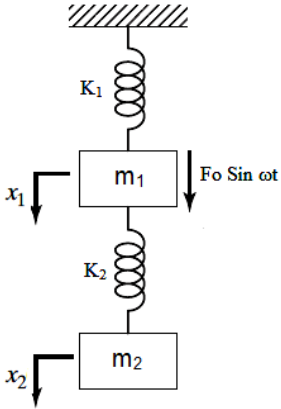
	 <p>Fig. Q 6(b)</p>				
--	--	--	--	--	--

**Unit III**

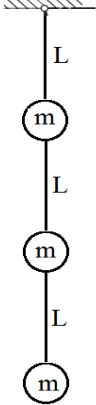
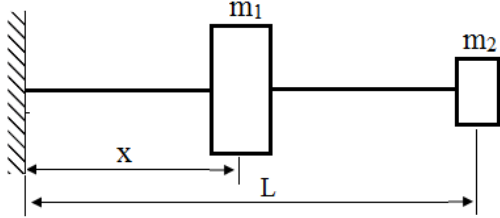
7 a)	<p>Determine the fundamental natural frequency for the triple pendulum shown in Fig. Q 7(a) using matrix iteration method. Take <math>a_{11} = a_{12} = a_{13} = L/3mg</math>, <math>a_{22} = a_{23} = 5L/6mg</math> and <math>a_{33} = 11 L/6mg</math>.</p> <div style="text-align: center;">  </div> <p>Fig. Q 7(a)</p>	10	CO6	L3	2.1.3
7 b)	<p>Find the fundamental natural frequency of transverse vibration for the system shown in Fig. Q 7(b) using Rayleigh's method. Take <math>m_1 = 80</math> kg, <math>m_2 = 40</math> kg, <math>x = 0.25m</math>, <math>L = 0.4</math> m, <math>E = 200</math> GPa and <math>I = 4 \times 10^{-7}</math> m<sup>4</sup>.</p> <div style="text-align: center;">  </div> <p>Fig. Q 7(b)</p>	10	CO6	L3	2.3.1
8 a)	<p>Explain in detail the procedure of experimental modal analysis with necessary hardware components.</p>	10	CO7	L2	1.4.1
8 b)	<p>Explain with sketch seismic instruments. It is desired to measure the maximum acceleration of a machine part which vibrates violently with a frequency of 700 cpm. Accelerometer attached to it has a mass of 0.05 kg and spring constant of 1800 N/m. Total travel of the accelerometer indicator is 8.2 mm. Determine the maximum amplitude and maximum acceleration of the vibrating part.</p>	10	CO7	L2	1.4.1

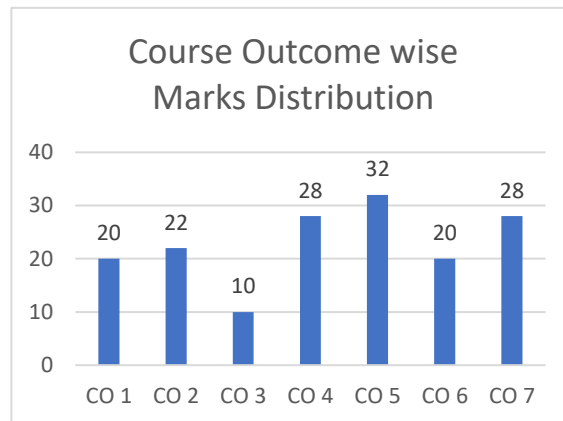
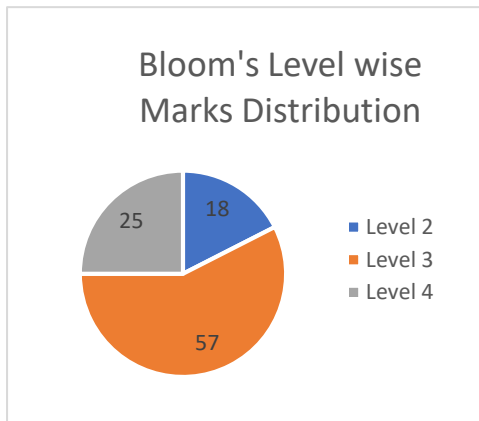

**BL – Bloom's Taxonomy Levels (1- Remembering, 2- Understanding, 3 – Applying, 4 – Analysing, 5 – Evaluating, 6 - Creating)**

**CO – Course Outcomes**

**PO – Program Outcomes; PI Code – Performance Indicator Code**

## Course Name: Mechanics of Materials

### Course Outcomes (CO):

1. Analyze the state of internal effects caused by external loads acting on real bodies that undergoes deformation (stress & strain).
2. Determine the strength and characteristics of materials and understand the design uncertainties involved in design problem.
3. Compute the deformation of variety of structural members and design components subjected to axial loading.
4. Analyze Torsional stress and angle of twist in circular shafts used for power transformation.
5. Draw shear and moment diagrams of simple beams subjected to various loading conditions.
6. Apply the flexural formula to simple structures to calculate the bending stress.
7. Determine the shear stresses produced by non uniform bending.
8. Compute deflection of beams.

**Model Question Paper**  
**Total Duration (H:M):3:00**  
**Course :Mechanics of Materials**  
**Maximum Marks :100**

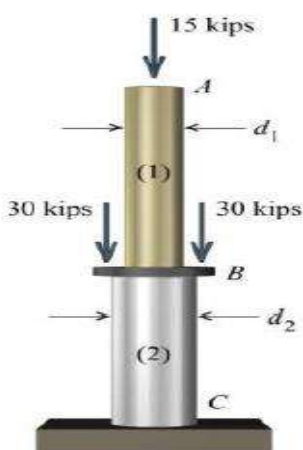
Q. No.	Questions	Marks	CO	BL	PI
1a	<p>Two solid cylindrical rods (1) and (2) are joined together at flange <i>B</i> and loaded, as shown in Figure Q.1a. The diameter of rod (1) is 1.75 in. and the diameter of rod (2) is 2.50 in. Determine the normal stresses in rods (1) and (2).</p>  <p style="text-align: center;">Figure Q.1a</p>	10	CO1	L3	1.3.1
1b	<p>The five-bolt connection shown in Figure Q.1b must support an applied load of <math>P = 265</math> kN. If the average shear stress in the bolts must be limited to 120 MPa, determine the minimum bolt diameter that may be used for this connection.</p>	05	CO1	L3	1.3.1

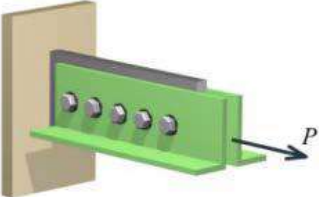
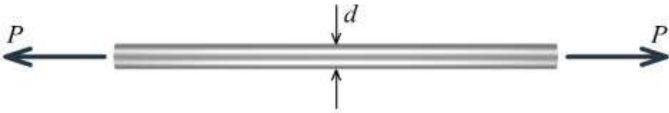
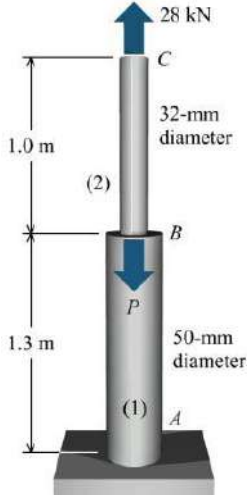

	 <p style="text-align: center;">Figure Q.1b</p>				
1c	<p>State the Hook's law. Neatly draw the Stress-strain diagram for Steel indicating all silent points and zones on it.</p>	05	CO2	L2	1.3.1
2a	<p>At an axial load of 22 kN, a 45-mm-wide × 15-mm-thick polyimide polymer bar elongates 3.0 mm while the bar width contracts 0.25 mm. The bar is 200 mm long. At the 22-kN load, the stress in the polymer bar is less than its proportional limit. Determine: (a) the modulus of elasticity, (b) Poisson's ratio, (c) the change in the bar thickness</p>	10	CO2	L3	1.3.1
2b	<p>A solid circular rod with a diameter of <math>d = 16</math> mm is shown in Figure Q.2b. The rod is made of an aluminum alloy that has an elastic modulus of <math>E = 72</math> GPa and Poisson's ratio of <math>\nu = 0.33</math>. When subjected to the axial load <math>P</math>, the diameter of the rod decreases by 0.024 mm. Determine the magnitude of load <math>P</math></p>  <p style="text-align: center;">Figure Q.2b</p>	10	CO2	L3	1.3.1
3a	<p>With standard notations derive the expression for deformation of axially loaded bars of uniform cross-section</p>	10	CO3	L3	1.3.1
3b	<p>Aluminum [<math>E = 70</math> GPa] member ABC supports a load of 28 kN, as shown in Figure Q.3b. Determine:                  (a) the value of load <math>P</math> such that the deflection of joint C is zero.                  (b) the corresponding deflection of joint B.</p>  <p style="text-align: center;">Figure Q.3b</p>	10	CO3	L3	1.3.1
4a	<p>A solid steel [<math>G = 80</math> GPa] shaft of variable diameter is subjected to the torques shown in Figure Q.4a. The diameter of the shaft in segments (1) and (3) is 50 mm, and the diameter of the shaft in segment (2) is 80 mm. The bearings shown allow the shaft to turn freely. Determine the maximum shear stress in the compound shaft.</p>	10	CO4	L3	1.3.1

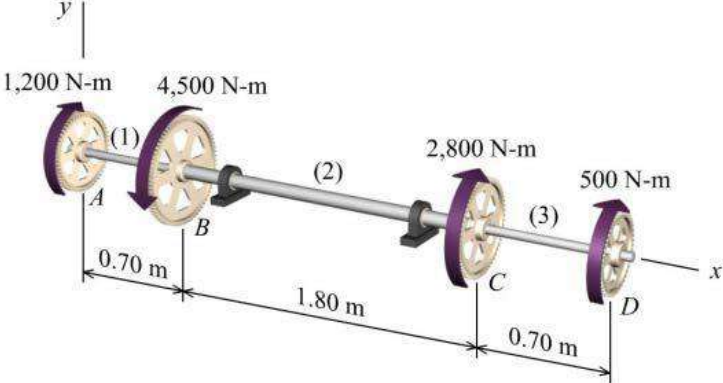
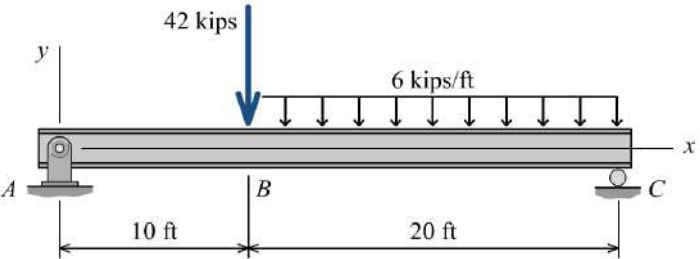
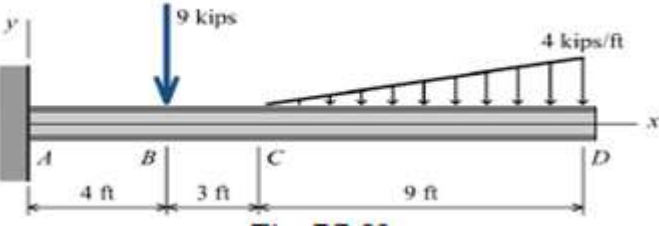
	 <p style="text-align: center;">Figure Q.4a</p>				
<p>4b</p>	<p>A tubular steel [<math>G = 80 \text{ GPa}</math>] shaft is being designed to transmit 150 kW at 30 Hz. The maximum shear stress in the shaft must not exceed 80 MPa and the angle of twist is not to exceed <math>6^\circ</math> in a 4-m length. Determine the minimum permissible outside diameter if the ratio of the inside diameter to the outside diameter is 0.80.</p>	<p>10</p>	<p>CO4</p>	<p>L3</p>	<p>1.3.1</p>
<p>5a</p>	<p>For the simply supported beam subjected to the loading shown in figure Q. 5a,</p> <p>(a) Derive equations for the shear force <math>V</math> and the bending moment <math>M</math> for any location in the beam. (Place the origin at point A.)</p> <p>(b) Plot the shear-force and bending-moment diagrams for the beam using the derived functions.</p> <p>(c) Report the maximum bending moment and its location.</p>  <p style="text-align: center;">Figure Q. 5a</p>	<p>10</p>	<p>CO5</p>	<p>L3</p>	<p>1.3.1</p>
<p>5b</p>	<p>Use the graphical method to construct the shear-force and bending-moment diagrams for the beam shown in figure Q.5b . Label all significant points on each diagram and identify the maximum moments along with their respective locations. Clearly differentiate straight-line and curved portions of the diagrams.</p>  <p style="text-align: center;">Figure Q.5b</p>	<p>10</p>	<p>CO5</p>	<p>L3</p>	<p>1.3.1</p>
<p>6a</p>	<p>A beam having a tee-shaped cross section is subjected to equal 12 kN-m bending moments, as shown in Figure Q.6a. The cross-sectional</p>	<p>10</p>	<p>CO6</p>	<p>L3</p>	<p>1.3.1</p>

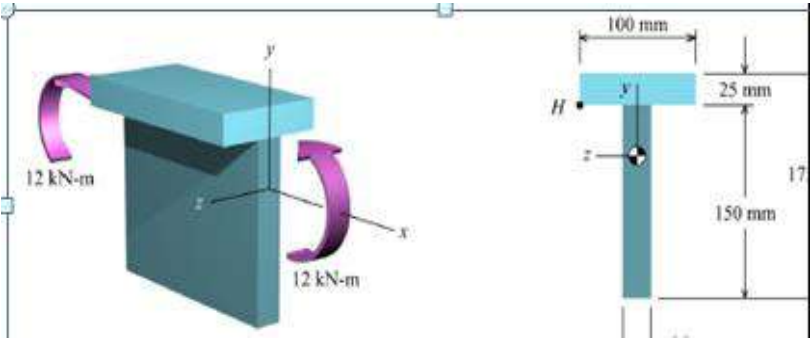
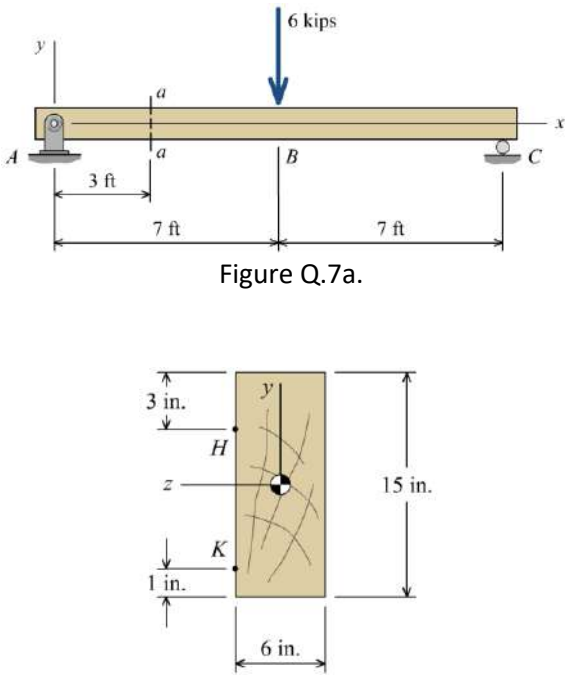
	<p>dimensions of the beam are shown in Figure Q.6b. Determine: (a) the centroid location, the moment of inertia about the z axis. (b) the maximum bending stress produced in the cross section. State whether the stress is tension or compression.</p>  <p style="text-align: center;">Figure Q.6a <span style="margin-left: 200px;">Figure Q.6b</span></p>				
6b	Derive the flexural formula for a beam subjected to pure bending.	10	CO6	L2	1.3.1
7a	<p>A 14-ft long simply supported timber beam carries a 6-kip concentrated load at mid span, as shown in Figure Q.7a. The cross-sectional dimensions of the timber are shown in Figure Q.7b.</p> <p>(a) At section <i>a-a</i>, determine the magnitude of the shear stress in the beam at point <i>H</i>.</p> <p>(b) Determine the maximum horizontal shear stress that occurs in the beam at any location within the 14-ft span length.</p>  <p style="text-align: center;">Figure Q.7a.   Figure Q.7b.</p>	10	CO7	L3	1.3.1
7b	<p>For the following problems, a beam segment subjected to internal bending moments at sections A and B is shown along with a sketch of the cross-sectional dimensions. Determine (a) the resultant forces acting in the x direction on the specified area at sections A and B and show these resultant forces on the sketch.</p>	10	CO7	L3	1.3.1

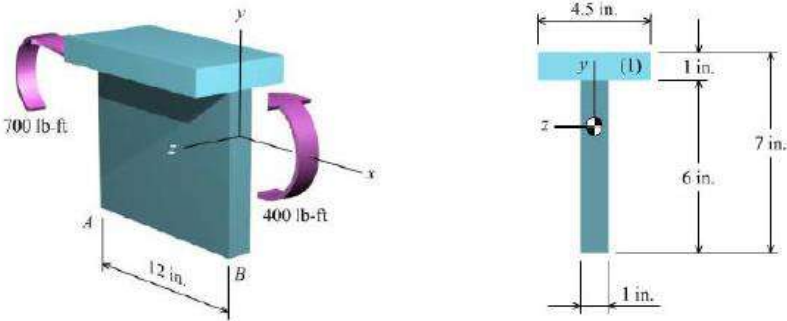
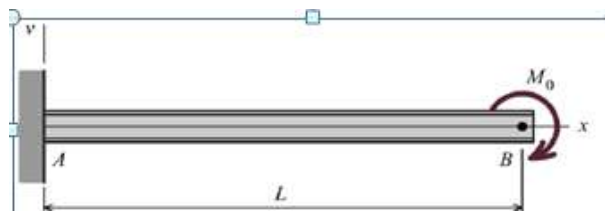
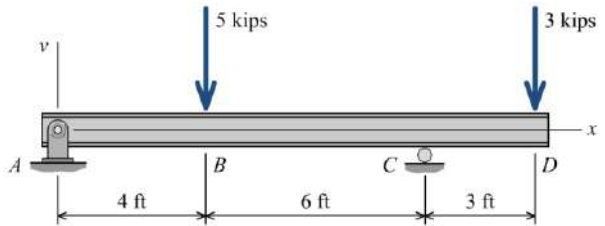
	<p>(b) Is the specified area in equilibrium with respect to forces acting in the x direction? If not, determine the horizontal force required to satisfy equilibrium for the specified area and show the location and direction of this force on the sketch</p> 				
<p>8a</p>	<p>For the loading shown in Figure Q. 8a, use the double-integration method to determine (a) the equation of the elastic curve for the cantilever beam, (b) the deflection at the free end. Assume that <math>EI</math> is constant for each beam.</p>  <p style="text-align: center;">Figure Q. 8a</p>	<p>10</p>	<p>CO8</p>	<p>L3</p>	<p>1.3.1</p>
<p>8b</p>	<p>For the beam and loading shown in Figure Q.8b, use discontinuity functions to compute the deflection of the beam at <math>D</math>. Assume a constant value of <math>EI = 1,750 \text{ kip-ft}^2</math> for the beam.</p>  <p style="text-align: center;">Figure Q.8b</p>	<p>10</p>	<p>CO8</p>	<p>L3</p>	<p>1.3.1</p>

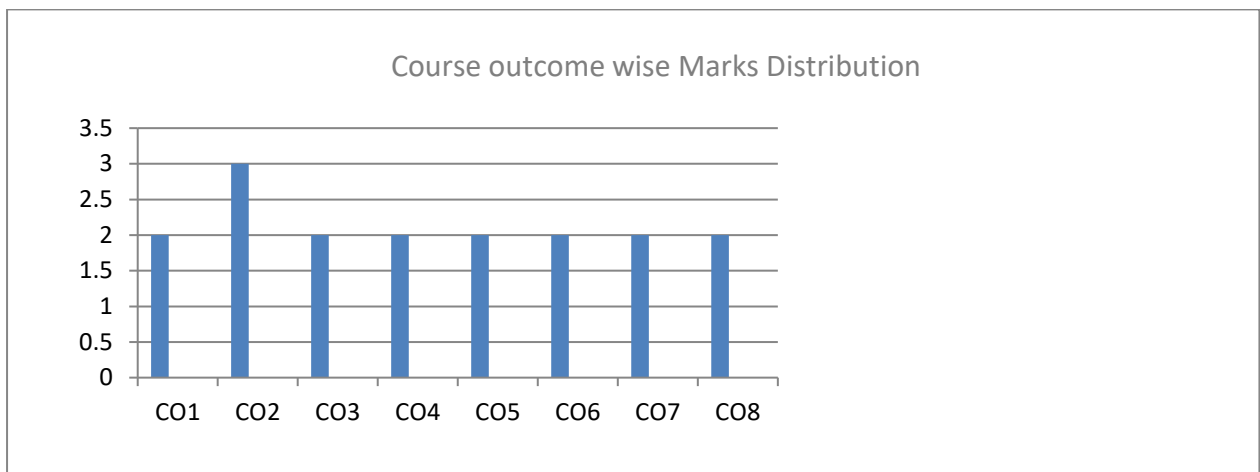
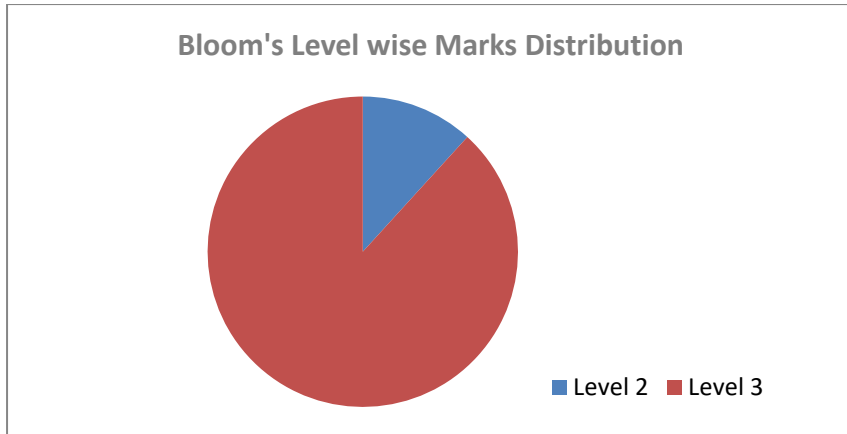

**BL – Bloom’s Taxonomy Levels (1- Remembering, 2- Understanding, 3 – Applying, 4 – Analysing, 5 – Evaluating, 6 - Creating)**

**CO – Course Outcomes**

**PO – Program Outcomes; PI Code – Performance Indicator Code**